

January 2011

ITP-UU-11-01

SPIN-11-01

Hybrid NLIE for the Mirror $\text{AdS}_5 \times \text{S}^5$

RYO SUZUKI

*Institute for Theoretical Physics and Spinoza Institute,
Utrecht University, 3508 TD Utrecht, The Netherlands*

Abstract

We revisit the derivation of hybrid nonlinear integral equations of the XXX model starting from the linearization of the T-system related to spinon variables. We obtain two sets of equations, corresponding to two linearly independent solutions of A_1 TQ-relation. Recalling that the TQ-relations in the horizontal strips of the $\mathfrak{su}(2|4|2)$ -hook is of A_1 type, we replace the corresponding Y-functions by a finite number of auxiliary variables.

Contents

1	Introduction and Summary	2
2	Hybrid NLIE in XXX model	6
2.1	Quantum transfer matrix in spin $k/2$ XXX model	6
2.2	Spinon variables	8
2.3	Decomposing the Y-system of XXX model	9
2.4	Analyticity conditions in the XXX model	11
3	Hybrid NLIE from TQ-relations	15
3.1	TQ-relation from Wronskian	15
3.2	Decomposing TBA from TQ-relations	17
3.3	Analyticity conditions in the horizontal strip	18
4	Discussion	21
A	Notations	23
B	Review of Y-system and T-system	24
C	Asymptotic solutions	26
C.1	Asymptotic transfer matrix	26
C.2	Asymptotic Wronskian formula	28
C.3	Analyticity data	30

1 Introduction and Summary

AdS/CFT is a conjecture dictating that the spectrum of $\text{AdS}_5 \times \text{S}^5$ is dual to the dimension of $D = 4$, $\mathcal{N} = 4$ SYM local operators [1]. The exact spectrum of both theories have recently been studied intensively based on integrability methods. One of the central ideas is Thermodynamic Bethe Ansatz (TBA) equations.¹ The TBA equations are used to compute the exact ground state energy of a finite-volume field theory by interchanging the space and time directions [5]. Such strategy was followed by the study of worldsheet theory with space- and time- coordinates interchanged [6]. This theory is also called mirror $\text{AdS}_5 \times \text{S}^5$ model, and thoroughly investigated in [7].

The partition function of the mirror $\text{AdS}_5 \times \text{S}^5$ can be computed by asymptotic Bethe Ansatz [8, 9] under the assumption called string hypothesis [4, 10]. Variational method is applicable in the thermodynamic limit, and the TBA equations arise as the condition for extremality [11, 12, 13]. The TBA consists of a set of nonlinear integral equations for Y-functions. Each Y-function corresponds to a particular type of boundstates which contribute to the mirror partition function.

In the meantime, Y-system on the $\mathfrak{su}(2|4|2)$ -hook has been proposed and solved explicitly in the asymptotic limit [14].² The Y-system is a set of difference equations for Y-functions, and the Y-system can be expressed as T-system, namely another set of difference equations for T-functions [17, 18]. The T-system is closely related to global symmetry of the given model [19, 16], and can be derived from simplified TBA equations by the ‘projection’ operator $(\log f) \star s_K^{-1} \equiv \log(f^+ f^-)$ [13, 20]. If proper analyticity data are provided, one can integrate the Y-system to obtain most of the TBA equations [21, 22], except for the formula for the exact energy.

The original TBA equations capture the exact ground state energy, which is zero in the case of AdS/CFT [23]. A common wisdom to compute the exact spectrum of excited states is to deform the integration contours in the TBA equations, which was observed first in integrable 2D vertex models [24] and later in perturbed CFT [25, 26]. Upon contour deformation, the integrals pick up additional terms coming from singularities of Y-functions. As such, the excited-state TBA equations depend on the state and the value of coupling constant under consideration [21]. Numerical study also indicates that (the gradient of) the exact energy may exhibit a noticeable change at the critical value of coupling constant [27].

As applications, the exact dimension of Konishi state has been computed numerically up

¹The TBA equations appeared first in [2] and generalized to the Heisenberg spin chain in [3, 4].

²By $\mathfrak{su}(2|4|2)$ -hook we always mean the T-hook drawn as Figure 2 in Appendix B. There are other T-hooks for $\mathfrak{su}(2|4|2)$ type, corresponding to different choices of Kac-Dynkin diagram. [15, 16].

to $\lambda \approx 664$ [28] and $\lambda \approx 2046$ [29], and it matches string theory results at strong coupling [30, 31, 32, 33]. Five-loop dimension of Konishi state has been obtained numerically [34] and analytically [35], which agrees with the prediction of the generalized Lüscher formula [36, 37, 38, 39], although no field theoretical computation has been done as in the four-loop case [40, 41, 42]. Such agreement has been extended to general twist-two states in the $\mathfrak{sl}(2)$ sector [43, 44]. At strong coupling, the Y-system can be solved by character formula [45], and the result agrees with the exact energy of semiclassical strings [46, 19]. See also [47, 48, 49, 50, 51] towards the exact spectrum of twisted theories.

Behind these successes of TBA there has always been a huge amount of numerical computation, because infinitely many Y-functions must be determined. Therefore, to simplify the spectral problem we need nonlinear integral equations (NLIE) for finitely many degrees of freedom. Several types of NLIE are known in other integrable models. For example, in the NLIE of Destri-de Vega (DdV) type, each integral is evaluated on the real axis (or a path around the real axis if there are branch cuts). Such NLIE was derived from Bethe Ansatz equations [52, 53, 54, 55] or from T-system [24, 56]. As another example, in the NLIE of Takahashi type, one unknown variable is integrated over a contour on the complex plane [57, 58]. The Takahashi-type NLIE consists of smaller number of equations than the NLIE of DdV type, but comprehensive understanding of the analyticity data is required for its formulation. In this paper we are interested in the DdV-type NLIE.

At first sight, it is not even clear if the NLIE for the mirror $\text{AdS}_5 \times \text{S}^5$ exists at all. A hint for the derivation of NLIE comes from the linearization of T-system by Q-functions [59]. The linearized equations, or so-called TQ-relations [60], have been studied a lot so far, and are solved by Bäcklund transformation [61, 62], or explicitly by the Wronskians of Q-functions [63, 64]. Remarkably, in the Wronskian formula all T-functions of $\mathfrak{su}(2|4|2)$ -hook are expressed by the Wronskian of eight fundamental Q-functions. It does not immediately imply, however, that the spectral problem gets simpler. In TBA it is enough to compute each Y-function on the real axis. In the Wronskian formula, each fundamental Q-function has to be evaluated on the whole complex plane. Hence, one more step is needed after having solved the TQ-relations.

Motivated to get something practical, we start investigating a mixture of NLIE and TBA, called hybrid NLIE. Hybrid NLIE was first formulated in the XXX model at spin $S = k/2$ [65], generalizing earlier successes of [52, 53]. The idea is to add auxiliary variables to the T-system such that the mixed system of equations is closed within a finite number of variables. The Y-function Y_k is replaced by $(1 + Y_k) = (1 + \mathbf{a})(1 + \bar{\mathbf{a}})$, where a pair of variables $\mathbf{a}, \bar{\mathbf{a}}$ represent the degrees of freedom of spinons, and all Y-functions $Y_{j>k}$ disappear from the equations.

Here the term ‘spinon’ is used in the following sense. According to [66], the S-matrix of

XXX spin chain at spin $S = k/2$ factorizes into the RSOS R-matrix at level k and the S-matrix of spin $\frac{1}{2}$ excitations. The former degree of freedom, called RSOS excitation, does not couple to external magnetic field. The latter degree of freedom, called spinon, couples to magnetic field. It turns out that only the auxiliary fields $\mathbf{a}, \bar{\mathbf{a}}$ are sensitive to magnetic field, while Y-functions are insensitive. Thus the auxiliary fields are identified as spinons [65].

When $k = 1$, there are further intimate relations between the auxiliary fields and ‘spinons’ in the usual sense, that is momentum-carrying excitations over the antiferromagnetic vacuum. For one thing, one can derive the character formula of $\widehat{\mathfrak{sl}(2)}_{k=1}$ as summation over spinons [67, 68]. For another, as mentioned in [69], the hybrid NLIE of XXX model at $k = 1$ reduces to the NLIE of Destri and de Vega [54, 55].³ In the DdV approach, the fundamental excitations are usual spinons, and we expect that the auxiliary fields of hybrid NLIE will play the same rôle. More insights have been found in the NLIE’s of $O(4)$ sigma model [69, 70, 71], sine-Gordon model [54, 55, 72, 73, 74] and other integrable lattice models [75, 76].

Summary of results

In this paper, we first revisit the derivation of hybrid NLIE in XXX model [65] in a slightly different way. We start our discussion from new recursion relations for spinon variables, instead of following computations using explicit form of T-functions. From these lessons we learn how to proceed in the $\text{AdS}_5 \times S^5$ case.⁴

Next, we repeat the discussions from the TQ-relations which appear in the horizontal strips ($|s| \geq 2$) of the $\mathfrak{su}(2|4|2)$ -hook. We derive a set of NLIE which decomposes the TBA equations for $Y_{M|w}$ -strings of the mirror $\text{AdS}_5 \times S^5$. This set of NLIE can be glued to the other parts of TBA equations together with the exact Bethe equation, and hence our formalism is hybrid. Using analyticity assumptions, the NLIE can be truncated within a finite number of variables.

In the literature, it is commonly recognized that TQ-relations are important to derive DdV-type NLIE (see for instance [56], or appendices of [77, 78]). Our discussions goes almost in parallel, but the derivation is a bit more general. We use the explicit form of T- and Q-functions only for checking analyticity assumptions, and the rest of arguments follows immediately from the symmetry structure of A_1 TQ-relations. Note that, in the integrable models studied so far, there is a gauge choice in which all T-functions on the boundary of A_1 -type strip are either

³At $k = 1$, Y-functions disappear from the hybrid NLIE, and thus the NLIE is no longer hybrid.

⁴An object called quantum transfer matrix was studied in [65]. In AdS/CFT, it is not known how to construct usual or quantum transfer matrices. With a different motivation in mind in contrast to [65], we consider the usual transfer matrix analytically continued to the mirror region as the asymptotic solution of T-system. Despite differences in the physical interpretation, the same mathematical techniques are applicable.

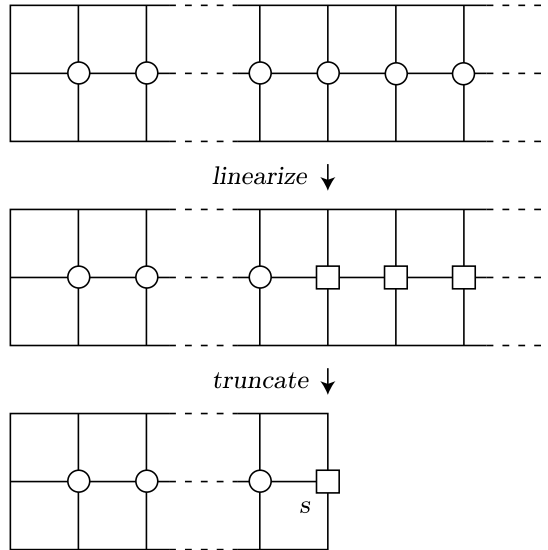

Figure 1: The horizontal strip of the $\mathfrak{su}(2|4|2)$ -hook. The symbol \square means the TBA equation for the corresponding site is decomposed. Under analyticity assumptions, we can excise the nodes of \square .

unity, or some known functions independent of Bethe roots.⁵ We do not use such conditions in the case of $\text{AdS}_5 \times \text{S}^5$, because it is unclear if there exists such a gauge choice.

To be specific, let us introduce a set of parameters for the hybrid NLIE as

$$\{Y_{1|w}, \dots, Y_{s-2|w}\} \cup \left\{ \begin{array}{l} \mathfrak{a}_s^\alpha \\ \bar{\mathfrak{a}}_s^\alpha \end{array} \right\}, \quad (s \geq 3), \quad (1.1)$$

where α is either I or II, and it refers to two linearly independent pairs of Q-functions that solve the TQ-relations. Our notation is summarized in Appendix A. The pair of variables $(\mathfrak{a}_s^\alpha, \bar{\mathfrak{a}}_s^\alpha)$ satisfy

$$1 + Y_{s-1|w} = (1 + \mathfrak{a}_s^{\alpha[+\gamma]})(1 + \bar{\mathfrak{a}}_s^{\alpha[-\gamma]}), \quad (1.2)$$

where γ is a small parameter for regularization. The parameter γ is arbitrary as long as $0 < \gamma < 1$, and it facilitates numerical computation. The parametrization (1.1) means that the TBA equation for $Y_{M|w}$ ($M \geq s$) are decomposed into an infinite set of NLIE for auxiliary variables. Furthermore, under the assumptions on analyticity (3.21), (3.24) and (3.28), we can truncate the NLIE for auxiliary variables at finite s . This structure is summarized in Figure 1

Below we summarize the minimal set of NLIE's in the case of Konishi state in the $\mathfrak{sl}(2)$ at weak coupling. We use the mirror TBA equations to determine $Y_Q, Y_{M|vw}, Y_\pm$, and also the

⁵There is another gauge in which the T-function on the boundary is a polynomial of a fixed degree.

exact Bethe equations to determine Bethe roots [12, 21]. The simplified TBA for $Y_{1|w}$ is given in [21], which we rewrite as

$$\log Y_{1|w} = \log(1 + \mathbf{a}_3^{\alpha[+\gamma]})(1 + \bar{\mathbf{a}}_3^{\alpha[-\gamma]}) \star s_K + \log \frac{1 - \frac{1}{Y_-}}{1 - \frac{1}{Y_+}} \hat{\star} s_K. \quad (1.3)$$

The pair of parameters $(\mathbf{a}_3^\alpha, \bar{\mathbf{a}}_3^\alpha)$ are determined by

$$\log \mathbf{a}_3^\alpha = \log(1 + \mathbf{a}_3^\alpha) \star K_f - \log(1 + \bar{\mathbf{a}}_3^\alpha) \star K_f^{[+2-2\gamma]} + \log(1 + Y_{1|w}^{[-\gamma]}) \star s_K + J_3^\alpha, \quad (1.4)$$

$$\log \bar{\mathbf{a}}_3^\alpha = \log(1 + \bar{\mathbf{a}}_3^\alpha) \star K_f - \log(1 + \mathbf{a}_3^\alpha) \star K_f^{[-2+2\gamma]} + \log(1 + Y_{1|w}^{[+\gamma]}) \star s_K + \bar{J}_3^\alpha, \quad (1.5)$$

where $J_3^I = \bar{J}_3^I = 0$ and

$$\begin{aligned} J_3^{\text{II}} &= -\log S_f(v) - \log S_f\left(v + \frac{2i(1-\gamma)}{g}\right) - \pi i, \\ \bar{J}_3^{\text{II}} &= +\log S_f(v) + \log S_f\left(v - \frac{2i(1-\gamma)}{g}\right) + \pi i, \end{aligned} \quad (1.6)$$

with possibly a multiple of $2\pi i$ in addition. The source terms (1.6) come from the branch cut discontinuity of $\log(1 + \mathbf{a}_3^{\text{II}})$, $\log(1 + \bar{\mathbf{a}}_3^{\text{II}})$ at the origin. These equations can be checked by using the asymptotic solution shown in Appendix C.

This paper is organized as follows. In Section 2, we review the derivation of hybrid NLIE in the XXX model, with a slight modification from [65]. In Section 3, we derive hybrid NLIE from TQ-relations in the horizontal strips of $\mathfrak{su}(2|4|2)$ -hook, which is of A_1 type. Section 4 is for discussions. In appendices, we summarize the notation, the relation between TBA, Y- and T-system of $\text{AdS}_5 \times S^5$, and the asymptotic solutions of recursion relations discussed in the main text.

2 Hybrid NLIE in XXX model

As a warm-up, we revisit the derivation of hybrid NLIE in the XXX model at spin $k/2$ [65].

2.1 Quantum transfer matrix in spin $k/2$ XXX model.

The quantum transfer matrix (QTM) is a method to compute the free-energy of spin $k/2$ XXX model at finite temperature without string hypothesis [79, 77]. In this method, we first map the XXX model of size L to two-dimensional vertex model of size $L \times R$, where R is called Trotter number [79, 77]. The time (or temperature) direction is replaced by a discrete spatial

direction. Then we consider states which look like M -particle state over ferromagnetic vacuum, and take the Trotter limit $R \rightarrow \infty$. In this limit, the largest eigenvalue of QTM T_k is equal to the free-energy at finite temperature, under appropriate identification of parameters. For instance, the number M also goes to infinity, with $M/R = k/2$ fixed.

Just like ordinary transfer matrix, QTM depends on the ‘mirror’ Bethe roots x_1, x_2, \dots, x_M . Since we do not postulate string hypothesis, we do not know their exact position. Instead, we compute the largest eigenvalue of QTM in the Trotter limit by solving a set of NLIE. We relegate the precise definition of QTM to [65, 80] and references therein, as we are interested in the algebraic structure, rather than the physical origin, of QTM.

Let us use the notation $f^{[+Q]} = f(v + iQ)$, $f^\pm = f^{[\pm 1]}$. The elementary QTM $T_1(v)$ reads [65]

$$T_1(v) = e^{\beta H} \phi_+^{[-k+1]} \phi_-^{[-k-1]} \frac{Q^{[+2]}}{Q} + e^{-\beta H} \phi_+^{[k+1]} \phi_-^{[k-1]} \frac{Q^{[-2]}}{Q}, \quad (2.1)$$

$$\phi_\pm(v) = (v \pm iu)^{R/2}, \quad Q(v) = \prod_{i=1}^M (v - x_i). \quad (2.2)$$

The QTM for higher representations satisfy the T-system equations (also called functional relations among the fusion hierarchy) [24, 17, 18],

$$T_j^+ T_j^- = T_{j-1} T_{j+1} + f_j, \quad f_j = \prod_{m=1}^j \prod_{\sigma=\pm} \phi_\sigma^{[\sigma(j-k-2m+1)]} \phi_\sigma^{[\sigma(-j+k+2m+1)]}, \quad (2.3)$$

with $j \geq 1$ and $T_0 = 1$. The temperature is related to the parameter u , which goes to zero in the Trotter limit. Explicit form of $T_j(v)$ reads [65]

$$T_j(v) = \sum_{\ell=1}^{j+1} \lambda_j^{(k)}(v, \ell) = \sum_{\ell=1}^{j+1} e^{\beta H(j+2-2\ell)} \psi_j^{(k)}(v, \ell) \frac{Q^{[j+1]} Q^{[-j-1]}}{Q^{[2\ell-j-1]} Q^{[2\ell-j-3]}}, \quad (2.4)$$

$$\psi_j^{(k)}(v, \ell) = \prod_{m=1}^{j-\ell+1} \phi_-^{[j-k-2m]} \phi_+^{[j-k+2-2m]} \times \prod_{m=1}^{\ell-1} \phi_-^{[-j+k-2+2m]} \phi_+^{[-j+k+2m]},$$

The T-system (2.3) is invariant under the gauge transformation

$$T_j \rightarrow g_1^{[+j]} g_2^{[-j]} T_j, \quad f_j \rightarrow g_1^{[j-1]} g_1^{[j+1]} g_2^{[-j+1]} g_2^{[-j-1]} f_j. \quad (2.5)$$

2.2 Spinon variables

We define auxiliary variables by the top and the bottom component of the sum in (2.4),

$$\begin{aligned} A_j(v) &= \lambda_j^{(k)}(v, j+1) = e^{-j\beta H} \psi_j^{(k)}(v, j+1) \frac{Q^{[-j-1]}}{Q^{[+j-1]}}, \\ \bar{A}_j(v) &= \lambda_j^{(k)}(v, 1) = e^{+j\beta H} \psi_j^{(k)}(v, 1) \frac{Q^{[+j+1]}}{Q^{[-j+1]}}. \end{aligned} \quad (2.6)$$

By X and \bar{X} we denote independent degrees of freedom. We will call them conjugate, as they are sometimes (but not always) complex conjugate with each other.

It is straightforward to check the following pair of recursion relations

$$T_j^+ - A_j^+ = \frac{\bar{A}_j^+}{\bar{A}_{j-1}} T_{j-1}, \quad T_j^- - \bar{A}_j^- = \frac{A_j^-}{A_{j-1}} T_{j-1}, \quad (j \geq 1), \quad (2.7)$$

with $A_0 = \bar{A}_0 = T_0 = 1$. To maintain the full gauge symmetry of the T-system, we require that A_j, \bar{A}_j behave in the same way as T_j under the gauge transformation (2.5). The ratio of two gauge-covariant variables are gauge-invariant,

$$\frac{T_j^+}{A_j^+} = 1 + \mathfrak{b}_j, \quad \frac{T_j^-}{\bar{A}_j^-} = 1 + \bar{\mathfrak{b}}_j. \quad (2.8)$$

Following the discussion of [65], we call A_j, \bar{A}_j or $\mathfrak{b}_j, \bar{\mathfrak{b}}_j$ spinon variables, and (2.7) covariant recursions for spinons. In the literature, the right hand side of (2.7) was recognized only as (something) $\times T_{j-1}$, with ‘something’ determined case by case. The new recursions (2.7) are the basis of the following discussions in this section.

The pair of recursions (2.7) with the definition of auxiliary variables (2.6) appear in various integrable models. For example, the QTM (2.1), (2.4) look similar to the ordinary transfer matrix of the XXX model and the $O(4)$ model [81, 69]. They differ only by the form of the function $\psi_j^{(k)}(v, \ell)$. Not surprisingly, the pair of covariant recursions (2.7) are satisfied with the definition of (2.6).

In fact, the recursions (2.7) follow from A_1 TQ-relations, as discussed later in Section 3.⁶ Let us identify

$$A_j^\alpha = \frac{\bar{Q}_{j-1}^{\alpha-}}{Q_{j-1}^{\alpha-}} L_j, \quad \bar{A}_j^\alpha = \frac{Q_{j-1}^{\alpha+}}{\bar{Q}_{j-1}^{\alpha+}} \bar{L}_j, \quad (\alpha = \text{I, II}), \quad (2.9)$$

where the index α refers to two linearly independent solutions of A_1 TQ-relations. In the (twisted) XXX model, the two sets of Q-functions are given by a polynomial of Bethe roots

⁶The author thanks Zoltan Bajnok for these remarks and suggestion for this identification.

and holes as (2.2) [82, 83, 84].⁷ The pair (A_j, \bar{A}_j) shown in (2.6) should correspond to the case of Bethe roots.

As shown in Appendix C, one can solve the recursions (2.7) by using the asymptotic transfer matrix $T_{a,1}$ in the $\mathfrak{sl}(2)$ sector, with the definition of A 's similar to (2.6). This also means that the asymptotic transfer matrix $T_{1,s}$ in the $\mathfrak{su}(2)$ sector satisfies the recursions in the same way, because the transfer matrices in the $\mathfrak{sl}(2)$ - and $\mathfrak{su}(2)$ -sectors are related by the flip $T_{a,s} \leftrightarrow T_{s,a}$ with the interchange $\pm \leftrightarrow \mp$.

2.3 Decomposing the Y-system of XXX model

Let us discuss the consequences of the covariant recursions for spinons (2.7).

First, using (2.7), we express T_{j+1} by T_{j-1} in two ways. The first expression is given through $T_{j+1} \rightarrow T_j^- \rightarrow T_{j-1}$, while the second expression is through $T_{j+1} \rightarrow T_j^+ \rightarrow T_{j-1}$. Since both results are equivalent, we obtain the compatibility condition

$$\Delta(A_j) = \Delta(\bar{A}_j) \equiv 1 + \mathfrak{X}_j, \quad \Delta(X_j) \equiv \frac{X_j^- X_j^+}{X_{j-1} X_{j+1}}. \quad (2.10)$$

The operator Δ is called discrete Laplacian. When this condition is satisfied, we obtain

$$T_j^- T_j^+ - (1 + \mathfrak{X}_j) T_{j-1} T_{j+1} = A_j^+ \bar{A}_j^-, \quad (2.11)$$

which is equivalent to the T-system (2.7) if

$$\mathfrak{X}_j = 0, \quad f_j = A_j^+ \bar{A}_j^-. \quad (2.12)$$

We set \mathfrak{X}_j to zero below, which is indeed true in all examples mentioned so far. Only then, the recursion pair (2.7) can be recognized as the linearization of the T-system. In the gauge-invariant language, the equation (2.11) translates into

$$(1 + \mathfrak{b}_j)(1 + \bar{\mathfrak{b}}_j) = 1 + Y_j, \quad 1 + Y_j \equiv \frac{T_j^- T_j^+}{f_j}. \quad (2.13)$$

Second, we rewrite the recursion in terms of \mathfrak{b} 's as

$$\mathfrak{b}_j = \frac{\bar{A}_j^+}{A_j^+} \frac{T_{j-1}}{\bar{A}_{j-1}} = \frac{1 + \mathfrak{b}_j}{1 + \bar{\mathfrak{b}}_j^{[+2]}} (1 + \bar{\mathfrak{b}}_{j-1}^+), \quad \bar{\mathfrak{b}}_j = \frac{A_j^-}{\bar{A}_j^-} \frac{T_{j-1}}{A_{j-1}} = \frac{1 + \bar{\mathfrak{b}}_j}{1 + \mathfrak{b}_j^{[-2]}} (1 + \mathfrak{b}_{j-1}^-). \quad (2.14)$$

⁷The term ‘hole’ refers to the excitations from the highest energy state of ferromagnetic nature, and not to the excitations from the antiferromagnetic state.

By taking the ratio $(\text{LHS})_{j+1}/(\text{LHS})_j^{\mp}$ we find the following recursion,

$$1 + \frac{1}{\mathfrak{b}_{j+1}^{\mp}} = \frac{1}{1 + \frac{1}{Y_j}} \left(1 + \frac{1}{\mathfrak{b}_j} \right), \quad 1 + \frac{1}{\overline{\mathfrak{b}}_{j+1}^{\mp}} = \frac{1}{1 + \frac{1}{Y_j}} \left(1 + \frac{1}{\overline{\mathfrak{b}}_j} \right). \quad (2.15)$$

Using (2.13) and (2.15), we can derive alternative expressions of gauge-invariant recursions,

$$\mathfrak{b}_j (1 + \overline{\mathfrak{b}}_{j+1}^+) = \overline{\mathfrak{b}}_j (1 + \mathfrak{b}_{j+1}^-) = Y_j. \quad (2.16)$$

Let us count the number of gauge-invariant variables and the number of equations. The list of gauge-invariant variables is given by

$$\{Y_1, Y_2, \dots, Y_{j-1}\} \cup \left\{ \begin{array}{c} \mathfrak{b}_j \\ \overline{\mathfrak{b}}_j \end{array} \right\}. \quad (2.17)$$

We define Y-functions by

$$\begin{aligned} 1 + Y_m &= \frac{T_m^- T_m^+}{f_m} & (m = 1, 2, \dots, j-1), \\ 1 + Y_m &= (1 + \mathfrak{b}_m) (1 + \overline{\mathfrak{b}}_m) & (m = j), \end{aligned} \quad (2.18)$$

where $j \geq 1$ is an arbitrary positive integer. Then, the T-system at site m is equivalent to the Y-system at site m ,

$$\begin{aligned} Y_m^- Y_m^+ &= (1 + Y_{m-1}) (1 + Y_{m+1}) & (m = 1, 2, \dots, j-2), \\ Y_{j-1}^- Y_{j-1}^+ &= (1 + Y_{j-2}) (1 + \mathfrak{b}_j) (1 + \overline{\mathfrak{b}}_j), \end{aligned} \quad (2.19)$$

where we used $Y_0 = 0$ and $f_m^- f_m^+ = f_{m-1} f_{m+1}$. There are $j-1$ Y-functions and a pair of auxiliary variables, while there are only $j-1$ equations in (2.19). Therefore two equations are missing.

One equation comes from the product of (2.14) as

$$\mathfrak{b}_j^- \overline{\mathfrak{b}}_j^+ = (1 + \mathfrak{b}_{j-1}) (1 + \overline{\mathfrak{b}}_{j-1}) = 1 + Y_{j-1}. \quad (2.20)$$

From algebraic point of view, there is no other way to relate $(\mathfrak{b}_j, \overline{\mathfrak{b}}_j)$ with Y_{j-1} . A closed set of equations can be obtained with the help of analyticity assumptions, which will be reviewed in Section 2.4.

One may try to enclose the equations by extending the parameter list, like

$$\{Y_1, Y_2, \dots, Y_{j-1}\} \cup \left\{ \begin{array}{cc} \mathfrak{b}_j & \mathfrak{b}_{j+1} \\ \overline{\mathfrak{b}}_j & \overline{\mathfrak{b}}_{j+1} \end{array} \right\}. \quad (2.21)$$

Now two more variables $(\mathbf{b}_{j+1}, \bar{\mathbf{b}}_{j+1})$ are introduced compared to (2.17). They are constrained by the recursion (2.15). Actually it is possible to find more than two equations: the equation (2.20) at $(j, j+1)$, the discrete Laplace equation for $(1 + \mathbf{b}_j)$, and the Y-system at site j . However, these extra equations never bring new constraints, because all of them follow from the algebraic relations we have already used. For example, the equation

$$\mathbf{b}_{j+1}^- \bar{\mathbf{b}}_{j+1}^+ = (1 + \mathbf{b}_j)(1 + \bar{\mathbf{b}}_j) = 1 + Y_j, \quad (2.22)$$

is a corollary of (2.13) and (2.15). The discrete Laplacian $\Delta(1 + \mathbf{b}_j) = 1 + 1/Y_j^+$ is a corollary of two recursions (2.14), (2.16). The Y-system at site j follows from (2.16), (2.20) as

$$Y_j^- Y_j^+ = \mathbf{b}_j^- (1 + \bar{\mathbf{b}}_{j+1}) \bar{\mathbf{b}}_j^+ (1 + \mathbf{b}_{j+1}) = (1 + Y_{j-1})(1 + Y_{j+1}). \quad (2.23)$$

Therefore, after having pondered over the parameter list (2.21), we again find that one variable is yet undetermined.

Similarly, we cannot get the one missing equation even if we extend the parameter list to

$$\{Y_1, Y_2, \dots, Y_{j-1}\} \cup \left\{ \begin{array}{cccc} \mathbf{b}_j & \mathbf{b}_{j+1} & \dots & \mathbf{b}_{j+\ell} \\ \bar{\mathbf{b}}_j & \bar{\mathbf{b}}_{j+1} & \dots & \bar{\mathbf{b}}_{j+\ell} \end{array} \right\}, \quad (2.24)$$

as long as ℓ is finite. When we take the limit $\ell \rightarrow \infty$, we will just find that the Y-system (or TBA equations) for $Y_{m \geq j}$ are decomposed into the NLIE for spinon variables.

2.4 Analyticity conditions in the XXX model

We derive two more equations from analyticity assumptions, following [65].

Let us evaluate the first equalities of (2.14) by using the explicit form of A 's (2.6),

$$\mathbf{b}_j = e^{+(j+1)\beta H} \frac{\psi_j^{(k)}(v+i, 1)}{\psi_j^{(k)}(v+i, j+1) \psi_{j-1}^{(k)}(v, 1)} \frac{Q^{[+j+2]}}{Q^{[-j]}} T_{j-1} \equiv W_j \frac{Q^{[+j+2]}}{Q^{[-j]}} T_{j-1}, \quad (2.25)$$

$$\bar{\mathbf{b}}_j = e^{-(j+1)\beta H} \frac{\psi_j^{(k)}(v-i, j+1)}{\psi_j^{(k)}(v-i, 1) \psi_{j-1}^{(k)}(v, j)} \frac{Q^{[-j-2]}}{Q^{[+j]}} T_{j-1} \equiv \bar{W}_j \frac{Q^{[-j-2]}}{Q^{[+j]}} T_{j-1}. \quad (2.26)$$

We want to take the Fourier transform of the logarithmic derivative of these equations, denoted as

$$\widehat{dl} f \equiv \int_{-\infty}^{\infty} dv e^{iqv} \frac{\partial}{\partial v} \log f(v). \quad (2.27)$$

The Fourier transform is well-defined only if there are no poles nor branch cuts over the path of integration. As for the left hand side of (2.25), (2.26), we introduce the regularization

$$\mathbf{a}_j(v) = \mathbf{b}_j(v - i\gamma), \quad \bar{\mathbf{a}}_j(v) = \bar{\mathbf{b}}_j(v + i\gamma), \quad (2.28)$$

with $\gamma > 0$ a small parameter, and take the Fourier transform on the real axis of $(\mathbf{a}_j(v), \bar{\mathbf{a}}_j(v))$. As for the right hand side, we assume the analyticity of each factor in (2.25) for $-\gamma \leq \text{Im } v \leq 0$, and similarly in (2.26) for $0 \leq \text{Im } v \leq +\gamma$.⁸ Then these equations become

$$\begin{aligned}\widehat{dl}\mathbf{a}_j &= e^{-\gamma q} \left\{ \widehat{dl}W_j + \widehat{dl}Q^{[+j+2]} - \widehat{dl}Q^{[-j]} + \widehat{dl}T_{j-1} \right\}, \\ \widehat{dl}\bar{\mathbf{a}}_j &= e^{+\gamma q} \left\{ \widehat{dl}\bar{W}_j + \widehat{dl}Q^{[-j-2]} - \widehat{dl}Q^{[+j]} + \widehat{dl}T_{j-1} \right\}.\end{aligned}\quad (2.29)$$

We will see later that $(\widehat{dl}Q^{[+j]}, \widehat{dl}Q^{[-j]})$ are related to $(\widehat{dl}(1 + \mathbf{b}_j) \hat{s}_K(q), \widehat{dl}(1 + \bar{\mathbf{b}}_j) \hat{s}_K(q))$, where

$$\hat{s}_K(q) = \int_{-\infty}^{\infty} dv e^{iqv} s_K(v) = \frac{1}{2 \cosh q}.\quad (2.30)$$

Here we rescaled the kernel s_K defined in (A.6) by a factor of g , because $f^\pm = f(v \pm i)$ in the XXX model.

The terms $\widehat{dl}Q^{[+j+2]}$ and $\widehat{dl}Q^{[-j-2]}$ in (2.29) are dangerous in the following sense. Under proper conditions, one may analytically continue them as

$$\widehat{dl}Q^{[+j+2]} = e^{+2q} \widehat{dl}Q^{[+j]}, \quad \widehat{dl}Q^{[-j-2]} = e^{-2q} \widehat{dl}Q^{[-j]}.\quad (2.31)$$

Then, the corresponding terms in (2.29) behave, in the limit $\text{Re } q \rightarrow \pm\infty$, as

$$\begin{aligned}e^{+2q} \widehat{dl}Q^{[+j]} &\sim \widehat{dl}(1 + \mathbf{b}_j) \hat{s}_K(q) e^{+2q} \rightarrow \frac{1}{2} \widehat{dl}(1 + \mathbf{b}_j) e^{+2q-|q|}, \\ e^{-2q} \widehat{dl}Q^{[-j]} &\sim \widehat{dl}(1 + \bar{\mathbf{b}}_j) \hat{s}_K(q) e^{-2q} \rightarrow \frac{1}{2} \widehat{dl}(1 + \bar{\mathbf{b}}_j) e^{-2q-|q|},\end{aligned}\quad (2.32)$$

which are exponentially growing. If one applies the inverse Fourier transform, one finds that the functions $(\log(1 + \mathbf{b}_j), \log(1 + \bar{\mathbf{b}}_j))$ are convoluted with the kernel which diverges exponentially as $\text{Re } v \rightarrow \pm\infty$. As discussed below, we use analyticity conditions such that both $\widehat{dl}Q^{[+j]}$ and $\widehat{dl}Q^{[-j]}$ vanish in the region where the kernels are exponentially growing.

ANZC conditions

We fix a gauge for the symmetry of T-system (2.5) by the explicit form of T_j in (2.4), and assume that in this gauge T-functions are analytic, nonzero and constant at infinity (ANZC), namely

$$T_j(v) \text{ is ANZC for } -1 \leq \text{Im } v \leq 1, \quad 1 \leq j \leq k.\quad (2.33)$$

⁸These assumptions are part of the analyticity conditions discussed later in (2.33), (2.38).

The upper bound for j comes from an empirical observation that $T_j(v)$ may have zeroes around the lines $\text{Im } v = \pm(k+2-j)$ [65]. Let D be a strip $|\text{Im } v| \leq 1$, and consider an integral running along the boundary of D . By virtue of the ANZC for $[\log T_j]'$, we find

$$\begin{aligned} 0 &= \int_{\partial D} dv e^{iqv} \frac{\partial}{\partial v} \log T_j(v) = e^{+q} \widehat{dl} T_j(v-i) - e^{-q} \widehat{dl} T_j(v+i), \\ &= e^{+q} \widehat{dl} \left((1 + \bar{\mathbf{b}}_j(v)) \bar{A}_j(v-i) \right) - e^{-q} \widehat{dl} \left((1 + \mathbf{b}_j(v)) A_j(v+i) \right). \end{aligned} \quad (2.34)$$

We assume that the Fourier transform of the logarithmic derivative of each factor is unambiguous, namely $1 + \mathbf{b}_j(v)$, $1 + \bar{\mathbf{b}}_j(v)$, $A_j(v+i)$ and $\bar{A}_j(v-i)$ do not have poles nor branch cuts on the real axis of v . Then we obtain⁹

$$0 = e^{+q} \widehat{dl}(1 + \bar{\mathbf{b}}_j) - e^{-q} \widehat{dl}(1 + \mathbf{b}_j) + e^{+q} \widehat{dl} \bar{A}_j^- - e^{-q} \widehat{dl} A_j^+. \quad (2.35)$$

The last two terms can be explicitly evaluated by using (2.6), as

$$0 = e^{+q} \widehat{dl}(1 + \bar{\mathbf{b}}_j) - e^{-q} \widehat{dl}(1 + \mathbf{b}_j) + 2 \cosh q \left(\widehat{dl} Q^{[+j]} - \widehat{dl} Q^{[-j]} \right) + \omega_j(q), \quad (2.36)$$

$$\omega_j(q) \equiv e^{+q} \widehat{dl} \psi_j^{(k)}(v-i, 1) - e^{-q} \widehat{dl} \psi_j^{(k)}(v+i, j+1). \quad (2.37)$$

Next we assume that, for $j \geq k$,

$$Q^{[+j]}(v) \text{ is ANZC for } \text{Im } v \geq 0 \quad Q^{[-j]}(v) \text{ is ANZC for } \text{Im } v \leq 0. \quad (2.38)$$

By closing the contour of Fourier integral over the upper or lower half plane, we find

$$\widehat{dl} Q^{[+j]}(q) = 0 \quad \text{for } \text{Re } q > 0, \quad \widehat{dl} Q^{[-j]}(q) = 0 \quad \text{for } \text{Re } q < 0. \quad (2.39)$$

The assumption $j \geq k$ comes from another empirical fact. It is expected that the zeroes of Q-functions lie around $\text{Im } v = k-1, k-3, \dots, -k+1$, forming k -strings. If so, the Q-functions are ANZC only outside the strip $-k+1 \leq \text{Im } v \leq k-1$ [65]. Now by applying the analyticity (2.38) to (2.36), we obtain for $j \geq k$,

$$\begin{aligned} \widehat{dl} Q^{[+j]}(q) &= \begin{cases} 0 & \text{Re } q > 0, \\ \left(+e^{-q} \widehat{dl}(1 + \mathbf{b}_j) - e^{+q} \widehat{dl}(1 + \bar{\mathbf{b}}_j) - \widehat{dl} \omega_j \right) \hat{s}_K(q) & \text{Re } q < 0, \end{cases} \\ \widehat{dl} \bar{Q}^{[-j]}(q) &= \begin{cases} \left(-e^{-q} \widehat{dl}(1 + \mathbf{b}_j) + e^{+q} \widehat{dl}(1 + \bar{\mathbf{b}}_j) + \widehat{dl} \omega_j \right) \hat{s}_K(q) & \text{Re } q > 0, \\ 0 & \text{Re } q < 0. \end{cases} \end{aligned} \quad (2.40)$$

⁹Here $A_j(v+i)$ is equivalent to $A_j^+ = A_j(v+i-i0)$ thanks to the analyticity assumption; similarly for \bar{A}_j^- .

When $q = 0$, the Fourier transform (2.27) is equal to the difference

$$\widehat{dl} f(q = 0) = \log f(+\infty) - \log f(-\infty),$$

which is not so important in computing the inverse Fourier transform.

For later use, we apply the regularization (2.28) to $(1 + \mathbf{b}_j), (1 + \overline{\mathbf{b}}_j)$. Provided that

$$\begin{aligned} 1 + \mathbf{b}_j(v) & \text{ is ANZC for } -\gamma \leq \text{Im } v \leq 0, \\ 1 + \overline{\mathbf{b}}_j(v) & \text{ is ANZC for } 0 \leq \text{Im } v \leq +\gamma, \end{aligned} \quad (2.41)$$

we obtain

$$\widehat{dl}(1 + \mathbf{b}_j) = e^{+\gamma q} \widehat{dl}(1 + \mathbf{a}_j), \quad \widehat{dl}(1 + \overline{\mathbf{b}}_j) = e^{-\gamma q} \widehat{dl}(1 + \overline{\mathbf{a}}_j). \quad (2.42)$$

Derivation of NLIE

We shall set $j = k$ to comply with the ANZC conditions of (2.33) and (2.38). Let us rewrite the T-function in the equations (2.29) by Y-functions using (2.33) and (2.18), as

$$\begin{aligned} e^{+\gamma q} \widehat{dl} \mathbf{a}_k &= \widehat{dl} W_k + e^{+2q} \widehat{dl} Q^{[+k]} - \widehat{dl} Q^{[-k]} + \left\{ \widehat{dl} f_{k-1} + \widehat{dl}(1 + Y_{k-1}) \right\} \hat{s}_K(q), \\ e^{-\gamma q} \widehat{dl} \overline{\mathbf{a}}_k &= \widehat{dl} \overline{W}_k + e^{-2q} \widehat{dl} Q^{[-k]} - \widehat{dl} Q^{[+k]} + \left\{ \widehat{dl} f_{k-1} + \widehat{dl}(1 + Y_{k-1}) \right\} \hat{s}_K(q), \end{aligned} \quad (2.43)$$

with $f_{k-1} = A_{k-1}^+ \overline{A}_{k-1}^- = \psi_{k-1}^{(k)}(v + i, k) \psi_{k-1}^{(k)}(v - i, 1)$. We then substitute the results (2.40), (2.42) into these equations, and find

$$\begin{aligned} \widehat{dl} \mathbf{a}_k &= \frac{e^{-|q|}}{2 \cosh q} \widehat{dl}(1 + \mathbf{a}_k) - \frac{e^{2q(1-\gamma)-|q|}}{2 \cosh q} \widehat{dl}(1 + \overline{\mathbf{a}}_k) + \frac{e^{-\gamma q}}{2 \cosh q} \widehat{dl}(1 + Y_{k-1}) \\ &+ e^{-\gamma q} \widehat{dl} W_k + \frac{e^{-\gamma q}}{2 \cosh q} \widehat{dl} f_{k-1} + \frac{e^{q(1-\gamma)-|q|}}{2 \cosh q} \widehat{dl} \omega_k, \end{aligned} \quad (2.44)$$

$$\begin{aligned} \widehat{dl} \overline{\mathbf{a}}_k &= \frac{e^{-|q|}}{2 \cosh q} \widehat{dl}(1 + \overline{\mathbf{a}}_k) - \frac{e^{-2q(1-\gamma)-|q|}}{2 \cosh q} \widehat{dl}(1 + \mathbf{a}_k) + \frac{e^{-\gamma q}}{2 \cosh q} \widehat{dl}(1 + Y_{k-1}) \\ &+ e^{+\gamma q} \widehat{dl} \overline{W}_k + \frac{e^{+\gamma q}}{2 \cosh q} \widehat{dl} f_{k-1} + \frac{e^{-q(1-\gamma)-|q|}}{2 \cosh q} \widehat{dl} \omega_k. \end{aligned} \quad (2.45)$$

The second lines of (2.44), (2.45) are known functions in the XXX model, so we can regard all of them as part of the source terms.¹⁰ By applying the inverse Fourier transform, we obtain the missing equations for hybrid NLIE. The results can be summarized as,

$$\log \mathbf{a}_k = \log(1 + \mathbf{a}_k) \star K_f - \log(1 + \overline{\mathbf{a}}_k) \star K_f^{[+2-2\gamma]} + \log(1 + Y_{k-1}^{[-\gamma]}) \star s_K + (\text{source}), \quad (2.46)$$

$$\log \overline{\mathbf{a}}_k = \log(1 + \overline{\mathbf{a}}_k) \star K_f - \log(1 + \mathbf{a}_k) \star K_f^{[-2+2\gamma]} + \log(1 + Y_{k-1}^{[+\gamma]}) \star s_K + (\text{source}), \quad (2.47)$$

¹⁰These extra terms will be studied carefully in Section 3.

where the analyticity of $Y_{k-1}(v)$ for $-\gamma \leq \text{Im } v \leq +\gamma$ is assumed, and the kernel K_f is defined by

$$K_f(v) = \frac{1}{2\pi i} \frac{\partial}{\partial v} \log S_f(v), \quad S_f(v) = \frac{\Gamma\left(\frac{2-iv}{4}\right) \Gamma\left(\frac{iv}{4}\right)}{\Gamma\left(-\frac{iv}{4}\right) \Gamma\left(\frac{2+iv}{4}\right)}. \quad (2.48)$$

In the limit $\gamma \rightarrow 0$ the kernels \tilde{s}_K and $K_f^{[\pm 2]}$ have a pole at the origin, and we need the principal value prescription as in (A.9). Numerical computation is easier if we leave $\gamma > 0$ finite. The source terms can be fixed by considering the asymptotic behavior $\text{Re } v \rightarrow \pm\infty$ [65].

The two NLIE (2.47) provides a closed set of equations for the minimal parameter list (2.17). The product type relation (2.20) is a corollary of (2.47),

$$\log \mathbf{a}_k^{[-1+\gamma]} \bar{\mathbf{a}}_k^{[+1-\gamma]} = \log(1 + Y_{k-1}). \quad (2.49)$$

Cancellation of the whole source terms can be checked from the explicit results of [65].

3 Hybrid NLIE from TQ-relations

We will derive the hybrid NLIE starting from TQ-relations in the horizontal strips of the $\mathfrak{su}(2|4|2)$ -hook. The TQ-relations will play the same rôle as the covariant recursions for spinons in Section 2. Since we also use the TBA equations for the mirror $\text{AdS}_5 \times \text{S}^5$ in the $\mathfrak{sl}(2)$ sector, we assume that all Y- and T-functions are invariant under the interchange $(a, s) \leftrightarrow (a, -s)$.¹¹

3.1 TQ-relation from Wronskian

First of all, we rederive the TQ-relations in the horizontal strip $s \geq 2$ of the $\mathfrak{su}(2|4|2)$ -hook, starting from the Wronskian formula of [64]. The formula says that the T-functions $T_{a,s}$ for $a = 0, 1, 2$ are given by

$$\begin{aligned} T_{0,s} &= \mathbf{Q}_{\emptyset}^{[-s]}, \\ T_{1,s} &= \mathbf{Q}_1^{[+s]} \mathbf{Q}_1^{[-s]} - \mathbf{Q}_2^{[-s]} \mathbf{Q}_2^{[+s]} \quad (s \geq 1), \\ T_{2,s} &= \mathbf{Q}_{12}^{[+s]} \mathbf{Q}_{12}^{[-s]} \quad (s \geq 2). \end{aligned} \quad (3.1)$$

By solving the T-system

$$T_{a,s}^- T_{a,s}^+ = T_{a,s-1} T_{a,s+1} + T_{a-1,s} T_{a+1,s}, \quad (3.2)$$

¹¹Recall that $T_{a,s}$ depend on gauge choice. It is helpful to introduce τ_a as in Appendix B to discuss $T_{a,s>0}$ and $T_{a,s<0}$ in a symmetric way.

at $(a = 1, s \geq 2)$, we find

$$Q_{12}^{[+s]} = \det \begin{pmatrix} Q_1^{[s+1]} & Q_2^{[s+1]} \\ Q_1^{[s-1]} & Q_2^{[s-1]} \end{pmatrix}, \quad Q_{\emptyset}^{[-s]} Q_{12}^{[-s]} = \det \begin{pmatrix} Q_1^{[-s-1]} & Q_2^{[-s-1]} \\ Q_1^{[-s+1]} & Q_2^{[-s+1]} \end{pmatrix}. \quad (3.3)$$

Given (3.1), one can derive the relations

$$\begin{aligned} Q_1^{[s-2]} T_{1,s} - Q_1^{[+s]} T_{1,s-1}^- &= Q_2^{[-s]} Q_{12}^{[s-1]}, \\ Q_1^{[-s+1]} T_{1,s} - Q_1^{[-s]} T_{1,s-1}^+ &= Q_2^{[+s]} \left(Q_{\emptyset}^{[-s+1]} Q_{12}^{[-s+1]} \right), \\ Q_2^{[s-2]} T_{1,s} - Q_2^{[+s]} T_{1,s-1}^- &= Q_1^{[-s]} Q_{12}^{[s-1]}, \\ Q_2^{[-s+2]} T_{1,s} - Q_2^{[-s]} T_{1,s-1}^+ &= Q_1^{[+s]} \left(Q_{\emptyset}^{[-s+1]} Q_{12}^{[-s+1]} \right), \end{aligned} \quad (3.4)$$

for $s \geq 2$. They can be summarized as the TQ-relations of A_1 theory [60]:

$$\begin{aligned} Q_{1,s-1}^{\alpha-} T_{1,s} - Q_{1,s}^{\alpha} T_{1,s-1}^- &= \overline{Q}_{1,s-1}^{\alpha-} L_{1,s}, \\ \overline{Q}_{1,s-1}^{\alpha+} T_{1,s} - \overline{Q}_{1,s}^{\alpha} T_{1,s-1}^+ &= Q_{1,s-1}^{\alpha+} \overline{L}_{1,s}, \end{aligned} \quad (3.5)$$

where

$$L_{1,s} = Q_{12}^{[s-1]}, \quad \overline{L}_{1,s} = Q_{\emptyset}^{[-s+1]} Q_{12}^{[-s+1]}, \quad (3.6)$$

and $\alpha = \text{I, II}$ refers to

$$(Q_{1,s}^{\text{I}}, \overline{Q}_{1,s}^{\text{I}}) = (Q_1^{[+s]}, Q_2^{[-s]}), \quad (Q_{1,s}^{\text{II}}, \overline{Q}_{1,s}^{\text{II}}) = (Q_2^{[+s]}, Q_1^{[-s]}). \quad (3.7)$$

From (3.6) it follows that

$$T_{2,s} T_{0,s} = L_{1,s}^+ \overline{L}_{1,s}^- \quad (s \geq 2). \quad (3.8)$$

We wrote down the TQ-relations (3.5) in a covariant way; the equations maintain the full gauge symmetry of the T-system, as long as $X_{1,s}$, *i.e.* any quantity with the lower index $(1, s)$, behaves in the same way as $T_{1,s}$. One can apply any gauge transformation $\Phi_{1,s}$ to them, and the equations remain invariant. Since the Q-functions were originally translationally invariant ($X_{1,s} = X_{1,s-1}^+$, $\overline{X}_{1,s} = \overline{X}_{1,s-1}^-$), the new Q-functions are now translationally invariant modulo gauge transformation,

$$\frac{L_{1,s}}{L_{1,s-1}^+} = \frac{Q_{1,s}^{\alpha}}{Q_{1,s-1}^{\alpha+}} = \frac{\Phi_{1,s}}{\Phi_{1,s-1}^+}, \quad \frac{\overline{L}_{1,s}}{\overline{L}_{1,s-1}^-} = \frac{\overline{Q}_{1,s}^{\alpha}}{\overline{Q}_{1,s-1}^{\alpha-}} = \frac{\Phi_{1,s}}{\Phi_{1,s-1}^-}, \quad \frac{\Phi_{1,s}^- \Phi_{1,s}^+}{\Phi_{1,s-1}^- \Phi_{1,s-1}^+} = 1. \quad (3.9)$$

These equations are valid for $s \geq 3$, because $(L_{1,s}, \overline{L}_{1,s})$ are not defined at $s = 1$. The last equation of (3.9) means that Φ is a gauge degree of freedom.

Now consider the inverse problem, that is to obtain Q -functions when $T_{1,s}$ are given for a certain range of s . If $(L_{1,s}, \bar{L}_{1,s})$ are also given, it reduces to the problem to solve some second-order difference equations [60]. To see this, we rearrange the first line (resp. the second line) of (3.5) into a difference equation for Q 's (resp. \bar{Q} 's) as

$$\frac{L_{1,s}^{[-2]} Q_{1,s}}{\Phi_{1,s}^{[-2]}} + \frac{L_{1,s} Q_{1,s}^{[-4]}}{\Phi_{1,s}^{[-4]}} - \frac{R_s Q_{1,s}^{[-2]}}{\Phi_{1,s}^{[-2]}} = 0, \quad \frac{\bar{L}_{1,s}^{[+2]} \bar{Q}_{1,s}}{\Phi_{1,s}^{[+2]}} + \frac{\bar{L}_{1,s} \bar{Q}_{1,s}^{[+4]}}{\Phi_{1,s}^{[+4]}} - \frac{\bar{R}_s \bar{Q}_{1,s}^{[+2]}}{\Phi_{1,s}^{[+2]}} = 0, \quad (3.10)$$

where

$$R_s = \frac{\Phi_{1,s-1}^-}{T_{1,s-1}^-} \left(\frac{L_{1,s} T_{1,s-2}^{[-2]}}{\Phi_{1,s-2}^{[-2]}} + \frac{L_{1,s}^{[-2]} T_{1,s}}{\Phi_{1,s}^{[-2]}} \right), \quad \bar{R}_s = \frac{\Phi_{s-1}^+}{T_{1,s-1}^+} \left(\frac{\bar{L}_{1,s} T_{1,s-2}^{[+2]}}{\Phi_{s-2}^{[+2]}} + \frac{\bar{L}_{1,s}^{[+2]} T_{1,s}}{\Phi_{1,s}^{[+2]}} \right). \quad (3.11)$$

In general, the second order difference equations have two linearly independent solutions, in agreement with (3.7).

In the spectral problem of $\text{AdS}_5 \times \text{S}^5$, we do not try to solve the difference equations (3.10), because we do not know the exact form of $(L_{1,s}, \bar{L}_{1,s})$. Instead, we will construct a set of hybrid NLIE from the covariant TQ-relations (3.5). To formulate hybrid NLIE, we use the analyticity data of the asymptotic solutions, which will be discussed in Appendix C.2.

3.2 Decomposing TBA from TQ-relations

In this subsection, we decompose the TBA equations (or the Y-system) of A_1 theory using TQ-relations. Just like (2.9), we introduce the ‘spinon’ variables by

$$A_{1,s}^\alpha = \frac{\bar{Q}_{1,s-1}^{\alpha-}}{Q_{1,s-1}^{\alpha-}} L_{1,s}, \quad \bar{A}_{1,s}^\alpha = \frac{Q_{1,s-1}^{\alpha+}}{Q_{1,s-1}^{\alpha+}} \bar{L}_{1,s}, \quad (s \geq 2, \alpha = \text{I, II}), \quad (3.12)$$

and simplify the covariant A_1 TQ-relations (3.5) as

$$T_{1,s}^+ - A_{1,s}^{\alpha+} = \frac{\bar{A}_{1,s}^{\alpha+}}{A_{1,s-1}^{\alpha+}} T_{1,s-1}, \quad T_{1,s}^- - \bar{A}_{1,s}^{\alpha-} = \frac{A_{1,s}^{\alpha-}}{A_{1,s-1}^{\alpha-}} T_{1,s-1}, \quad (s \geq 3). \quad (3.13)$$

The lower bound of s has increased by one, because $(L_{1,s}, \bar{L}_{1,s})$ are defined only for $s \geq 2$.

Following Section 2.3, let us define new gauge-invariant variables by

$$1 + \mathfrak{b}_s^\alpha = \frac{T_{1,s}^+}{A_{1,s}^{\alpha+}} = \frac{Q_{1,s-1}^\alpha T_{1,s}^+}{Q_{1,s-1}^\alpha L_{1,s}^+}, \quad 1 + \bar{\mathfrak{b}}_s^\alpha = \frac{T_{1,s}^-}{A_{1,s}^{\alpha-}} = \frac{\bar{Q}_{1,s-1}^\alpha T_{1,s}^-}{Q_{1,s-1}^\alpha \bar{L}_{1,s}^-}, \quad (s \geq 2), \quad (3.14)$$

and count the number of variables and the number of equations. The Y-functions $Y_{1,M \geq s}$ are now replaced by

$$(1 + \mathfrak{b}_M^\alpha)(1 + \bar{\mathfrak{b}}_M^\alpha) = \frac{T_{1,M}^- T_{1,M}^+}{T_{0,M} T_{2,M}} = 1 + Y_{1,M}, \quad (\alpha = \text{I, II}). \quad (3.15)$$

This procedure corresponds to the middle of Figure 1, where the TBA equations are decomposed into new degrees of freedom.

Unfortunately, as discussed in Section 2.3, there is always one more unknown variables than the number of the equations that can be derived algebraically. For example, one can consider the general parameter list

$$\{Y_{1,2}, \dots, Y_{1,s-1}\} \cup \left\{ \begin{array}{cccc} \mathbf{b}_s^\alpha & \mathbf{b}_{s+1}^\alpha & \cdots & \mathbf{b}_{s+l}^\alpha \\ \bar{\mathbf{b}}_s^\alpha & \bar{\mathbf{b}}_{s+1}^\alpha & \cdots & \bar{\mathbf{b}}_{s+l}^\alpha \end{array} \right\}, \quad (s \geq 3), \quad (3.16)$$

where α is either I or II. Just like (2.24), the equations cannot be closed as long as ℓ is finite. In other words, the equations can be closed if in the limit $\ell \rightarrow \infty$ we require that $\lim_{s \rightarrow \infty} (\mathbf{b}_s, \bar{\mathbf{b}}_s)$ approach the asymptotic functions.¹² This conclusion is unchanged even if one includes both $\alpha = \text{I, II}$ in the above parameter list.

The shortage of one equation can be understood as follows. As we saw in Section 3.1, the most general solution of T-system or TQ-relations is given by fundamental Q-functions. However, it also implies that there is no equation which determines the fundamental Q-functions in an algebraic manner. To supply more constraints, we need to study analyticity conditions.

3.3 Analyticity conditions in the horizontal strip

We repeat the discussion in Section 2.4 in the case of the horizontal part of the $\mathfrak{su}(2|4|2)$ -hook. Although the asymptotic Q-functions on the $\mathfrak{su}(2|4|2)$ -hook are different from those of the XXX model, both of them have good analytic properties on the upper or lower half of the complex rapidity plane.

From (3.13), we can derive the relation

$$\mathbf{b}_s^\alpha = \frac{\bar{A}_{1,s}^{\alpha+}}{A_{1,s}^{\alpha+}} \frac{T_{1,s-1}}{\bar{A}_{1,s-1}^\alpha} = \frac{Q_{1,s-1}^{\alpha[+2]} T_{1,s-1}}{\bar{Q}_{1,s-1}^\alpha L_{1,s-1}^{[+2]}}, \quad (3.17)$$

$$\bar{\mathbf{b}}_s^\alpha = \frac{A_{1,s}^{\alpha-}}{\bar{A}_{1,s}^{\alpha-}} \frac{T_{1,s-1}}{A_{1,s-1}^\alpha} = \frac{\bar{Q}_{1,s-1}^{\alpha[-2]} T_{1,s-1}}{Q_{1,s-1}^\alpha \bar{L}_{1,s-1}^{[-2]}}, \quad (3.18)$$

for $s \geq 3$. We take the Fourier transform of the logarithmic derivative. As for the left hand side, we introduce the regularization

$$\mathbf{a}_s^\alpha(v) = \mathbf{b}_s^\alpha \left(v - \frac{i\gamma}{g} \right), \quad \bar{\mathbf{a}}_s^\alpha(v) = \bar{\mathbf{b}}_s^\alpha \left(v + \frac{i\gamma}{g} \right), \quad 0 < \gamma < 1, \quad (3.19)$$

and take the Fourier transform on the real axis of $(\mathbf{a}_s(v), \bar{\mathbf{a}}_s(v))$. The upper bound of γ comes from the definition of \mathbf{b} 's in (3.14); for instance, the variable $L_{1,s}^{[+1-\gamma]}$ should stay on the upper

¹²See [46, 35] for the discussion on boundary conditions of $Y_{a,s}$ as $a \rightarrow \infty$ or $s \rightarrow \infty$.

half plane. As for the right hand side, we assume that each factor in (3.17) is analytic inside the strip $-\frac{\gamma}{g} \leq \text{Im } v \leq 0$, and each factor in (3.18) is analytic inside the strip $0 \leq \text{Im } v \leq +\frac{\gamma}{g}$.¹³ Then we obtain, for $s \geq 3$,

$$\begin{aligned}\widehat{dl}\mathbf{a}_s^\alpha &= e^{-\gamma\frac{q}{g}} \left\{ \widehat{dl}Q_{1,s-1}^{\alpha[+2]} - \widehat{dl}\overline{Q}_{1,s-1}^\alpha - \widehat{dl}L_{1,s-1}^{[+2]} + \widehat{dl}T_{1,s-1} \right\}, \\ \widehat{dl}\overline{\mathbf{a}}_s^\alpha &= e^{+\gamma\frac{q}{g}} \left\{ \widehat{dl}\overline{Q}_{1,s-1}^{\alpha[-2]} - \widehat{dl}Q_{1,s-1}^\alpha - \widehat{dl}\overline{L}_{1,s-1}^{[-2]} + \widehat{dl}T_{1,s-1} \right\}.\end{aligned}\quad (3.20)$$

Note that the terms $\widehat{dl}Q_{1,s-1}^{\alpha[+2]}$, $\widehat{dl}\overline{Q}_{1,s-1}^{\alpha[-2]}$ are again as dangerous as in (2.32).

ANZC conditions

We assume that the analyticity data of the relevant functions are same as in the asymptotic case. The asymptotic expressions for $T_{1,s}$, $L_{1,s}$, $\overline{L}_{1,s}$ are discussed in Appendix C. We use the gauge $T_{1,s} = \text{TH}_{1,s}$ and set $\Phi_{1,s} = 1$.¹⁴

Suppose that for $s \geq 2$,

$$T_{1,s}(v) \text{ is ANZC for } -\frac{1}{g} \leq \text{Im } v \leq \frac{1}{g}.\quad (3.21)$$

Following the same argument as before, and keeping in mind the definition of \mathbf{b} 's in (3.14) and f^\pm in (A.1), we obtain

$$\begin{aligned}0 &= e^{+\frac{q}{g}} \widehat{dl}T_{1,s}^- - e^{-\frac{q}{g}} \widehat{dl}T_{1,s}^+, \\ &= e^{+\frac{q}{g}} \widehat{dl} \left\{ (1 + \overline{\mathbf{b}}_s^\alpha) \overline{L}_{1,s}^- \frac{Q_{1,s-1}^\alpha}{\overline{Q}_{1,s-1}^\alpha} \right\} - e^{-\frac{q}{g}} \widehat{dl} \left\{ (1 + \mathbf{b}_s^\alpha) L_{1,s}^+ \frac{\overline{Q}_{1,s-1}^\alpha}{Q_{1,s-1}^\alpha} \right\}.\end{aligned}\quad (3.22)$$

If the Fourier transform of the logarithmic derivative of each factor is well-defined, we get

$$\begin{aligned}0 &= e^{+\frac{q}{g}} \widehat{dl}(1 + \overline{\mathbf{b}}_s^\alpha) - e^{-\frac{q}{g}} \widehat{dl}(1 + \mathbf{b}_s^\alpha) \\ &\quad + 2 \cosh\left(\frac{q}{g}\right) \left(\widehat{dl}Q_{1,s-1}^\alpha - \widehat{dl}\overline{Q}_{1,s-1}^\alpha \right) + e^{+\frac{q}{g}} \widehat{dl}\overline{L}_{1,s}^- - e^{-\frac{q}{g}} \widehat{dl}L_{1,s}^+.\end{aligned}\quad (3.23)$$

We also assume that for $s \geq 3$,

$$\begin{aligned}Q_{1,s-1}^\alpha(v) \text{ is ANZC for } \text{Im } v \geq 0, & \quad \overline{Q}_{1,s-1}^\alpha(v) \text{ is ANZC for } \text{Im } v \leq 0, \\ L_{1,s-1}(v) \text{ is ANZC for } \text{Im } v \geq +\frac{1}{g}, & \quad \overline{L}_{1,s-1}(v) \text{ is ANZC for } \text{Im } v \leq -\frac{1}{g}.\end{aligned}\quad (3.24)$$

¹³Again, these assumptions are part of the analyticity conditions we will use below.

¹⁴This is equivalent to $\Theta_{1,s} = 1$ in the notation of Appendix C.

As corollaries, it follows that

$$\begin{aligned}\widehat{dl}Q_{1,s-1}^\alpha(q) &= 0 \quad \text{for } \text{Re } q > 0, & \widehat{dl}\overline{Q}_{1,s-1}^\alpha(q) &= 0 \quad \text{for } \text{Re } q < 0, \\ \widehat{dl}L_{1,s-1}^+(q) &= 0 \quad \text{for } \text{Re } q > 0, & \widehat{dl}\overline{L}_{1,s-1}^-(q) &= 0 \quad \text{for } \text{Re } q < 0.\end{aligned}\quad (3.25)$$

By using the analyticity and the translational properties (3.9) for the gauge $\Phi_{1,s} = 1$, we find

$$e^{-\frac{a}{g}} \widehat{dl}L_{1,s}^+ = e^{-\frac{a}{g}} \widehat{dl}L_{1,s-1}^{[+2]} = \widehat{dl}L_{1,s-1}^+, \quad e^{+\frac{a}{g}} \widehat{dl}\overline{L}_{1,s}^- = e^{+\frac{a}{g}} \widehat{dl}\overline{L}_{1,s-1}^{[-2]} = \widehat{dl}\overline{L}_{1,s-1}^-. \quad (3.26)$$

The equation (3.23) leads to

$$\begin{aligned}\widehat{dl}Q_{1,s-1}^\alpha - \widehat{dl}L_{1,s-1}^+ \hat{s}_K(q) &= \begin{cases} 0 & \text{Re } q > 0, \\ \left(-e^{+\frac{a}{g}} \widehat{dl}(1 + \overline{\mathfrak{b}}_s^\alpha) + e^{-\frac{a}{g}} \widehat{dl}(1 + \mathfrak{b}_s^\alpha) \right) \hat{s}_K(q) & \text{Re } q < 0, \end{cases} \\ \widehat{dl}\overline{Q}_{1,s-1}^\alpha - \widehat{dl}\overline{L}_{1,s-1}^- \hat{s}_K(q) &= \begin{cases} \left(-e^{-\frac{a}{g}} \widehat{dl}(1 + \mathfrak{b}_s^\alpha) + e^{+\frac{a}{g}} \widehat{dl}(1 + \overline{\mathfrak{b}}_s^\alpha) \right) \hat{s}_K(q) & \text{Re } q > 0, \\ 0 & \text{Re } q < 0. \end{cases}\end{aligned}\quad (3.27)$$

We employ the regularization (3.19) also for $(1 + \mathfrak{b}_s)$, $(1 + \overline{\mathfrak{b}}_s)$, assuming that

$$\begin{aligned}1 + \mathfrak{b}_s(v) &\text{ is ANZC for } -\frac{\gamma}{g} \leq \text{Im } v \leq 0, \\ 1 + \overline{\mathfrak{b}}_s(v) &\text{ is ANZC for } 0 \leq \text{Im } v \leq +\frac{\gamma}{g}.\end{aligned}\quad (3.28)$$

It follows that

$$\widehat{dl}(1 + \mathfrak{b}_s) = e^{+\gamma\frac{a}{g}} \widehat{dl}(1 + \mathfrak{a}_s), \quad \widehat{dl}(1 + \overline{\mathfrak{b}}_s) = e^{-\gamma\frac{a}{g}} \widehat{dl}(1 + \overline{\mathfrak{a}}_s). \quad (3.29)$$

Derivation of NLIE

Let us rewrite T-function into Y-function (3.15) using analyticity (3.21),

$$\widehat{dl}T_{1,s-1} = \left(\widehat{dl}L_{1,s-1}^+ + \widehat{dl}\overline{L}_{1,s-1}^- + \widehat{dl}(1 + Y_{1,s-1}) \right) \hat{s}_K(q), \quad s \geq 3. \quad (3.30)$$

The equation (3.20) then simplifies with the help of (3.24), and we obtain

$$\begin{aligned}e^{+\gamma\frac{a}{g}} \widehat{dl}\mathfrak{a}_s^\alpha &= e^{+\frac{2a}{g}} \left[\widehat{dl}Q_{1,s-1}^\alpha - \widehat{dl}L_{1,s-1}^+ \hat{s}_K(q) \right] \\ &\quad - \left[\widehat{dl}\overline{Q}_{1,s-1}^\alpha - \widehat{dl}\overline{L}_{1,s-1}^- \hat{s}_K(q) \right] + \widehat{dl}(1 + Y_{1,s-1}) \hat{s}_K(q), \\ e^{-\gamma\frac{a}{g}} \widehat{dl}\overline{\mathfrak{a}}_s^\alpha &= e^{-\frac{2a}{g}} \left[\widehat{dl}\overline{Q}_{1,s-1}^\alpha - \widehat{dl}\overline{L}_{1,s-1}^- \hat{s}_K(q) \right] \\ &\quad - \left[\widehat{dl}Q_{1,s-1}^\alpha - \widehat{dl}L_{1,s-1}^+ \hat{s}_K(q) \right] + \widehat{dl}(1 + Y_{1,s-1}) \hat{s}_K(q).\end{aligned}\quad (3.31)$$

We substitute (3.27) to these equations, keeping in mind that the terms in the square brackets are identical to the combination we found in (3.27). Recalling also (2.42), we find

$$\begin{aligned}\widehat{dl} \mathbf{a}_s^\alpha &= \frac{e^{-|\frac{q}{g}|}}{2 \cosh \frac{q}{g}} \widehat{dl}(1 + \mathbf{a}_s^\alpha) - \frac{e^{+2\frac{q}{g}(1-\gamma)-|\frac{q}{g}|}}{2 \cosh \frac{q}{g}} \widehat{dl}(1 + \bar{\mathbf{a}}_s^\alpha) + \frac{e^{-\gamma\frac{q}{g}}}{2 \cosh \frac{q}{g}} \widehat{dl}(1 + Y_{1,s-1}), \\ \widehat{dl} \bar{\mathbf{a}}_s^\alpha &= \frac{e^{-|\frac{q}{g}|}}{2 \cosh \frac{q}{g}} \widehat{dl}(1 + \bar{\mathbf{a}}_s^\alpha) - \frac{e^{-2\frac{q}{g}(1-\gamma)-|\frac{q}{g}|}}{2 \cosh \frac{q}{g}} \widehat{dl}(1 + \mathbf{a}_s^\alpha) + \frac{e^{-\gamma\frac{q}{g}}}{2 \cosh \frac{q}{g}} \widehat{dl}(1 + Y_{1,s-1}).\end{aligned}\quad (3.32)$$

The inverse Fourier transform gives

$$\begin{aligned}\log \mathbf{a}_s^\alpha &= \log(1 + \mathbf{a}_s^\alpha) \star K_f - \log(1 + \bar{\mathbf{a}}_s^\alpha) \star K_f^{[+2-2\gamma]} + \log(1 + Y_{1,s-1}^{[-\gamma]}) \star s_K + (\text{source}), \\ \log \bar{\mathbf{a}}_s^\alpha &= \log(1 + \bar{\mathbf{a}}_s^\alpha) \star K_f - \log(1 + \mathbf{a}_s^\alpha) \star K_f^{[-2+2\gamma]} + \log(1 + Y_{1,s-1}^{[+\gamma]}) \star s_K + (\text{source}),\end{aligned}\quad (3.33)$$

where the kernel K_f is now defined by (A.7), and the source terms can be fixed by analyticity data, as done in Introduction.

In summary, the minimal parameter list for the horizontal strips of the $\mathfrak{su}(2|4|2)$ -hook is

$$\{Y_{1|w}, \dots, Y_{s-2|w}\} \cup \left\{ \begin{array}{c} \mathbf{a}_s \\ \bar{\mathbf{a}}_s \end{array} \right\}, \quad (s \geq 3). \quad (3.34)$$

We cannot remove $Y_{1|w}$, because the pair $(\mathbf{a}_2, \bar{\mathbf{a}}_2)$ are not related to $Y_{1,1} = -1/Y_-$ in (3.20).¹⁵ To determine $\{Y_{1|w}, \dots, Y_{s-2|w}\}$, we use the simplified TBA for $Y_{M|w}$ ($M = 1, \dots, s-3$),

$$\log Y_{1,M+1} = \log(1 + Y_{1,M})(1 + Y_{1,M+2}) \star s_K + \delta_{M,1} \log \frac{1 - \frac{1}{Y_-}}{1 - \frac{1}{Y_+}} \hat{\star} s_K, \quad (3.35)$$

with $Y_{0|w} = 0$, and as for $Y_{s-2|w}$

$$\log Y_{s-2|w} = \log(1 + Y_{s-3|w})(1 + \mathbf{a}_s^{\alpha[+\gamma]})(1 + \bar{\mathbf{a}}_s^{\alpha[-\gamma]}) \star s_K + \delta_{s-2,1} \log \frac{1 - \frac{1}{Y_-}}{1 - \frac{1}{Y_+}} \hat{\star} s_K. \quad (3.36)$$

The NLIE (3.33) are used to determine $(\mathbf{a}_s, \bar{\mathbf{a}}_s)$.

4 Discussion

In this paper, we derived hybrid NLIE from two setups. The first setup was a pair of covariant recursions for spinons, and the second setup was A_1 TQ-relations. The A_1 TQ-relations

¹⁵In fact, we can find $\frac{T_{1,1}^+ T_{1,1}^-}{L_{1,1}^+ \bar{L}_{1,1}^-} = \frac{1-1/Y_-}{1-1/Y_+}$, if we use the asymptotic formulae of $L_{1,s}, \bar{L}_{1,s}$ at $s = 1$.

appeared in the horizontal strips of the $\mathfrak{su}(2|4|2)$ -hook. By combining TBA equations and the equations for auxiliary variables, we replaced the TBA equations for $Y_{M|w}$ for $M \geq 2$ by a couple of auxiliary variables. We used the assumptions (3.21), (3.24) and (3.28).

The hybrid NLIE provides us with an efficient algorithm to compute the exact spectrum of $\text{AdS}_5 \times S^5$ string theory, both numerically and analytically. It is desirable to develop similar techniques to truncate the vertical strip $a \geq 2$ of the $\mathfrak{su}(2|4|2)$ -hook, by generalizing TQ-relations and hybrid NLIE for a higher-rank system [60, 85, 86]. In the horizontal strip, the analyticity data were relatively simple, and the source terms in NLIE have simple structure. In the vertical strip, however, the analytic structure would be much complicated.

It is interesting to clarify the physical and mathematical interpretation of new auxiliary degrees of freedom. The relation (1.2) suggests that the $M|w$ -strings appearing in the string hypothesis of the mirror $\text{AdS}_5 \times S^5$ are boundstates of two fundamental excitations; like mesons and quarks. Moreover, the $\mathfrak{su}(2|4|2)$ -hook is replaced by another hook as in Figure 1, which would have deeper relation with representation theory of $\mathfrak{su}(2|4|2)$, like [68]. Such observation might give us a hint in searching for hidden structure of the mirror $\text{AdS}_5 \times S^5$ theory, along the line of [87, 88, 89, 90, 91, 92, 93].

Note added in v4

After the submission to arXiv, we are reminded of the talk [94] in Stockholm, where another way to truncate the horizontal wings was announced. The claim is as follows. By choosing a suitable gauge, one can assume that the exact T-function $T_{1,s}$ is given by the ansatz¹⁶

$$T_{1,s}(v) = s + \int_{-\infty}^{+\infty} dt K_s(v-t)f(t), \quad (s \geq 1). \quad (4.1)$$

The variable f is the density responsible for the discontinuities of $T_{1,s}$, and this unknown variable is determined by solving¹⁷

$$\frac{1 + Y_{1,1}}{1 + 1/Y_{2,2}} = \frac{T_{1,1}^- T_{1,1}^+ T_{2,3}}{T_{2,2}^- T_{2,2}^+ T_{0,1}} = \frac{(1 + K_1^+ \star_{p.v.} f + f/2)(1 + K_1^- \star_{p.v.} f + f/2)}{(1 + K_1^+ \star_{p.v.} f - f/2)(1 + K_1^- \star_{p.v.} f - f/2)}. \quad (4.2)$$

The equation (4.2), allows us to truncate the horizontal strips of the $\mathfrak{su}(2|4|2)$ -hook, and this result is claimed to be consistent with the numerical data for Konishi state for $0 \lesssim \lambda \lesssim 1000$.

¹⁶Reasoning for this ansatz has recently been explained in [95]. The author thanks N. Gromov, S. Leurent and D. Volin for discussions about this method.

¹⁷Here the definition of f^\pm can be different from (A.1).

Acknowledgements

The author acknowledges Sergey Frolov, Gleb Arutyunov and Zoltan Bajnok for helpful discussions throughout this project. The author thanks Junji Suzuki and Andreas Klümper for comments on the draft. He also thanks to the organizers of *Workshop on Integrable Quantum Systems* for an inspiring talk of [96]. This work is support by the Netherlands Organization for Scientific Research (NWO) under the VICI grant 680-47-602.

A Notations

We use the notation

$$g = \frac{\sqrt{\lambda}}{2\pi}, \quad f(v)^{[\pm m]} \equiv f\left(v \pm \frac{im}{g} \mp i0\right), \quad f(v)^\pm = f(v)^{[\pm 1]}, \quad (\text{A.1})$$

$$x_s(v) = \frac{v}{2} \left(1 + \sqrt{1 - \frac{4}{v^2}}\right), \quad x(v) = \frac{1}{2} \left(v - i\sqrt{4 - v^2}\right). \quad (\text{A.2})$$

Let us define

$$\mathcal{R}_{(\pm)}(v) = \prod_{j=1}^K \frac{x(v) - x_{s,j}^\pm}{\sqrt{x_{s,j}^\pm}}, \quad \mathcal{B}_{(\pm)}(v) = \prod_{j=1}^K \frac{\frac{1}{x(v)} - x_{s,j}^\pm}{\sqrt{x_{s,j}^\pm}}, \quad \mathcal{Q}(v) = \prod_{j=1}^K (v - u_j), \quad (\text{A.3})$$

where K is the number of physical excitations and $x_{s,j}^\pm = x_s(u_j \pm \frac{i}{g})$. The rapidity u_j sits in the physical region of string theory.¹⁸ There are identities

$$\mathcal{R}_{(\pm)}^{[m]}(v) \mathcal{B}_{(\pm)}^{[m]}(v) = (-1)^K \mathcal{Q}\left(v + \frac{i}{g}(m \mp Q_j)\right), \quad \mathcal{R}_{(+)}^+ \mathcal{B}_{(+)}^+ = \mathcal{R}_{(-)}^- \mathcal{B}_{(-)}^- = (-1)^K \mathcal{Q}. \quad (\text{A.4})$$

Since $x(v) = x_s(v)$ for $\text{Im } v < 0$ and $1/x(v) = x_s(v)$ for $\text{Im } v > 0$, we observe that

$$\mathcal{R}_{(\pm)}(v) \text{ have no zeroes for } \text{Im } v > 0, \quad \mathcal{B}_{(\pm)}(v) \text{ have no zeroes for } \text{Im } v < 0. \quad (\text{A.5})$$

The zeroes of $\mathcal{Q}(v)$ lie on the real axis of v if there are no boundstates. The branch cuts of \mathcal{R}, \mathcal{B} lie along the real axis of v .

We use the kernel

$$s_K(v) = \frac{g}{4 \cosh \frac{\pi g v}{2}}, \quad \tilde{s}_K = s_K^- = -s_K^+, \quad (\text{A.6})$$

$$K_f(v) = \frac{1}{2\pi i} \frac{\partial}{\partial v} \log S_f(v), \quad S_f(v) = \frac{\Gamma\left(\frac{g}{4i}\left(v + \frac{2i}{g}\right)\right) \Gamma\left(-\frac{g v}{4i}\right)}{\Gamma\left(\frac{g v}{4i}\right) \Gamma\left(-\frac{g}{4i}\left(v - \frac{2i}{g}\right)\right)}, \quad (\text{A.7})$$

¹⁸Our definition of (\pm) is different from [14, 12, 28].

and the notation

$$F \star K(v) = \int_{-\infty}^{\infty} dt F(t) K(v-t), \quad F \hat{\star} K(v) = \int_{-2}^2 dt F(t) K(v-t). \quad (\text{A.8})$$

Note that all kernels in (A.7) are symmetric, $K(v) = K(-v)$. The asymptotic behavior of $S_f(v)$ is $S_f(v) \rightarrow \mp i$ as $v \rightarrow \pm\infty$.

As for the convolution with \tilde{s}_K and $K_f^{[\pm 2]}$, one may use the principal-value prescription:

$$\begin{aligned} \log f^{\mp} \star s_K &= \frac{1}{2} \log f \mp \log f \star_{p.v.} \tilde{s}_K, \\ \log f \star K_f^{[+2\pm 0]} &= \mp \frac{1}{2} \log f + \log f \star_{p.v.} K_f^{[+2]}, \\ \log f \star K_f^{[-2\pm 0]} &= \pm \frac{1}{2} \log f + \log f \star_{p.v.} K_f^{[-2]}. \end{aligned} \quad (\text{A.9})$$

B Review of Y-system and T-system

Most of the mirror TBA equations on $\text{AdS}_5 \times \text{S}^5$, except for the exact energy and the exact Bethe roots, can be regarded as the Y-system on $\mathfrak{su}(2|4|2)$ supplemented by certain analyticity conditions. The canonical definition of the $\mathfrak{su}(2|4|2)$ Y-system is

$$Y_{a,s}^+ Y_{a,s}^- = \frac{(1 + Y_{a,s+1})(1 + Y_{a,s-1})}{\left(1 + \frac{1}{Y_{a+1,s}}\right) \left(1 + \frac{1}{Y_{a-1,s}}\right)}, \quad v \in (-2, 2), \quad (\text{B.1})$$

where (a, s) runs through the lattice points shown in Figure 2.

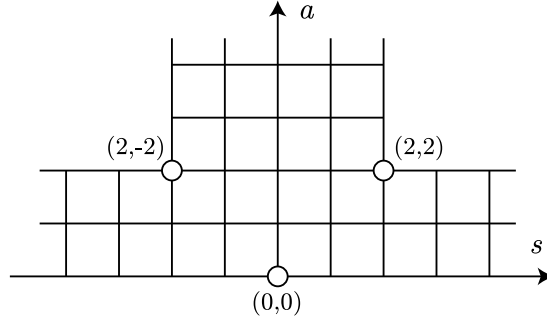

Figure 2: The $\mathfrak{su}(2|4|2)$ -hook, whose boundaries lie along $(0, s)$, $(2, s)$, $(a, \pm 2)$.

We assume the interchange symmetry $(a, s) \leftrightarrow (a, -s)$ in what follows. The Y-functions $Y_{a,s}$ are defined by

$$\begin{aligned} Y_{1,1} &\leftrightarrow -\frac{1}{Y_-}, \quad Y_{2,2} \leftrightarrow -Y_+, \quad Y_{M+1,1} \leftrightarrow \frac{1}{Y_{M|vw}}, \quad Y_{1,M+1} \leftrightarrow Y_{M|w}, \\ Y_{Q,0} &\leftrightarrow Y_Q, \end{aligned} \quad (\text{B.2})$$

where we set chemical potentials to zero. We introduce the T-functions by

$$Y_{a,s} \equiv \begin{cases} \tau_a \frac{T_{a,1} T_{a,-1}}{T_{a+1,0} T_{a-1,0}} & (s = 0) \\ \frac{T_{a,s+1} T_{a,s-1}}{T_{a+1,s} T_{a-1,s}} & (s \neq 0). \end{cases} \quad \text{where } \frac{\tau_a^+ \tau_a^-}{\tau_{a+1} \tau_{a-1}} = 1, \quad (\text{B.3})$$

The canonical Y-system (B.1) are then solved by the T-system which live on the $\mathfrak{su}(2|4|2)$ -hook,

$$T_{a,s}^+ T_{a,s}^- = T_{a+1,s} T_{a-1,s} + T_{a,s+1} T_{a,s-1}, \quad (a \geq 1, s \neq 0), \quad (\text{B.4})$$

and the Y-system at $|s| = 0, 1$ are solved by

$$T_{a,0}^+ T_{a,0}^- = T_{a+1,0} T_{a-1,0} + \tau_a T_{a,1} T_{a,-1}, \quad (a \geq 1). \quad (\text{B.5})$$

we introduced an extra ‘gauge’ factor τ_a in order to take the asymptotic limit $\tau_a \rightarrow 0$ easily. By redefinition of $T_{a,s}$ ($s \neq 0$) one can recover the standard definition of T-system, as will be discussed later.

T-functions vanish outside the $\mathfrak{su}(2|4|2)$ -hook, $T_{-1,s} = T_{3,\pm Q} = T_{Q,\pm 3} = 0$ for $s \in \mathbb{Z}$, $Q \geq 3$. Along the boundary of the hook, the T-system reduces to the discrete Laplace equation without source term.

The T-system equations (B.4), (B.5) are invariant under the gauge transformation

$$T_{a,s} \rightarrow g_1^{[a+s]} g_2^{[a-s]} g_3^{[-a+s]} g_4^{[-a-s]} T_{a,s}, \quad (\text{B.6})$$

with τ_a left intact. We need two gauge degrees of freedom to impose the boundary conditions $T_{0,s} = 1$ for all s .

There are subtle points in the study of the exact spectrum from the Y- and T-system on the $\mathfrak{su}(2|4|2)$ -hook, compared to the study from the mirror TBA equations on $\text{AdS}_5 \times S^5$. Firstly, The Y-system at the corner $(a, s) = (2, \pm 2)$ does not follow directly from the mirror TBA. To derive them, we have to use the parametrization (B.3) and the T-system (B.4) except at the corner. Then, the T- and Y-system at the corner can be derived from the equations in the neighborhood. Secondly, if the mirror rapidity v lies $(-\infty, -2) \cup (2, \infty)$, the Y-system is no longer canonical, and we need to know the gap on branch cuts.¹⁹

Meaning of τ_a . There is no τ_a in the usual T-system, so one may wonder if the system above is equivalent to them. To show the equivalence we consider the following transformation²⁰

$$T_{a,s} \rightarrow \frac{T_{a,s}}{F_{a-s+1} F_{a-s+3} \cdots F_{a+s-3} F_{a+s-1}}, \quad s \geq 1, \quad (\text{B.7})$$

$$T_{a,s} \rightarrow T_{a,s}, \quad s \leq 0, \quad (\text{B.8})$$

¹⁹The Y-system remains canonical if we use $f^\pm = f(v \pm \frac{i}{g} + i0)$ or $f^\pm = f(v \pm \frac{i}{g} - i0)$ instead of (A.1) [23].

²⁰We thank Sergey Frolov for the explanation of this subsection.

where F_a are arbitrary functions satisfying

$$F_a^+ F_a^- = F_{a+1} F_{a-1}. \quad (\text{B.9})$$

Then it is not difficult to show that under this transformation the Y-functions with $s \neq 0$ are invariant. We can also do a similar transformation with the change $s \rightarrow -s$, so there are two independent set of functions F_a^L and F_a^R which can be used for this purpose. $Y_{a,0}$ transforms as

$$Y_{a,0} \rightarrow \frac{\tau_a}{F_a^L F_a^R} \frac{T_{a,1} T_{a,-1}}{T_{a+1,0} T_{a-1,0}}. \quad (\text{B.10})$$

Then, eqs.(B.4) are invariant, and (B.5) transforms as

$$T_{a,0}^+ T_{a,0}^- = T_{a+1,0} T_{a-1,0} + \frac{\tau_a}{F_a^L F_a^R} T_{a,1} T_{a,-1}. \quad (\text{B.11})$$

Thus, if we choose $F_a^L F_a^R = \tau_a$ we get the T-system in the usual form. This consideration shows that introducing τ_a is just a matter of convenience.

C Asymptotic solutions

C.1 Asymptotic transfer matrix

We will discuss the $\mathfrak{su}(2|2)$ transfer matrix for the totally symmetric representations on the level-one vacuum, namely when there are no auxiliary Bethe roots among the physical excitations. Via analytic continuation of the rapidity into the mirror region, this transfer matrix generates the solution of the excite-state TBA equations for the $\mathfrak{sl}(2)$ sector [21] in the asymptotic limit.

As discussed in [14, 97], such transfer matrices, here denoted by $T_{a,1}$, are given by

$$T_{a,1} = 1 + \frac{\mathcal{R}_{(-)}^{[-a]} \mathcal{B}_{(+)}^{[-a]}}{\mathcal{R}_{(-)}^{[+a]} \mathcal{B}_{(+)}^{[+a]}} - 2 \frac{\mathcal{R}_{(+)}^{[+a]}}{\mathcal{R}_{(-)}^{[+a]}} + \sum_{k=1}^{a-1} \left(-2 + \frac{\mathcal{R}_{(-)}^{[a-2k]}}{\mathcal{R}_{(+)}^{[a-2k]}} + \frac{\mathcal{B}_{(-)}^{[a-2k]}}{\mathcal{B}_{(+)}^{[a-2k]}} \right) \frac{\mathcal{R}_{(+)}^{[+a]} \mathcal{Q}^{[a-1-2k]}}{\mathcal{R}_{(-)}^{[+a]} \mathcal{Q}^{[a-1]}}. \quad (\text{C.1})$$

This formula consists of $4a$ terms, and only four terms lie outside the sum. It is possible to include all terms under summation, as

$$T_{a,1} = \sum_{k=0}^a \lambda_k^{(B1),a} + \sum_{k=1}^{a-1} \lambda_k^{(B2),a} - \sum_{k=0}^{a-1} \left(\lambda_k^{(F1),a} + \lambda_k^{(F2),a} \right), \quad (\text{C.2})$$

where

$$\begin{aligned} \lambda_k^{(B1),a} &= \frac{\mathcal{R}_{(-)}^{[a-2k]} \mathcal{R}_{(+)}^{[+a]} \mathcal{Q}^{[a-1-2k]}}{\mathcal{R}_{(+)}^{[a-2k]} \mathcal{R}_{(-)}^{[+a]} \mathcal{Q}^{[a-1]}}, & \lambda_k^{(B2),a} &= \frac{\mathcal{B}_{(-)}^{[a-2k]} \mathcal{R}_{(+)}^{[+a]} \mathcal{Q}^{[a-1-2k]}}{\mathcal{B}_{(+)}^{[a-2k]} \mathcal{R}_{(-)}^{[+a]} \mathcal{Q}^{[a-1]}}, \\ \lambda_k^{(F1),a} &= \lambda_k^{(F2),a} = \frac{\mathcal{R}_{(+)}^{[+a]} \mathcal{Q}^{[a-1-2k]}}{\mathcal{R}_{(-)}^{[+a]} \mathcal{Q}^{[a-1]}}. \end{aligned} \quad (\text{C.3})$$

The auxiliary variables in the vertical direction are defined by taking four terms out of $T_{a,1}$ as

$$A_{a,1} = \lambda_0^{(B1),a} + \lambda_1^{(B2),a} - \lambda_0^{(F1),a} - \lambda_0^{(F2),a} = \frac{\mathcal{R}_{(+)}^{[+a]}}{\mathcal{R}_{(-)}^{[+a]}} \left(\frac{\mathcal{R}_{(-)}^{[+a]}}{\mathcal{R}_{(+)}^{[+a]}} + \frac{\mathcal{R}_{(+)}^{[a-2]}}{\mathcal{R}_{(-)}^{[a-2]}} - 2 \right),$$

$$\bar{A}_{a,1} = \lambda_a^{(B1),a} + \lambda_{a-1}^{(B2),a} - \lambda_{a-1}^{(F1),a} - \lambda_{a-1}^{(F2),a} = \frac{\mathcal{Q}^{[-a+1]} \mathcal{R}_{(+)}^{[+a]}}{\mathcal{Q}^{[+a-1]} \mathcal{R}_{(-)}^{[+a]}} \left(\frac{\mathcal{B}_{(+)}^{[-a]}}{\mathcal{B}_{(-)}^{[-a]}} + \frac{\mathcal{B}_{(-)}^{[-a+2]}}{\mathcal{B}_{(+)}^{[-a+2]}} - 2 \right). \quad (\text{C.4})$$

It is easy to check that the covariant recursions (2.7) are satisfied for $a \geq 2$, under the condition $\mathfrak{X}_{a,1} = 0$.²¹ As a corollary, we find

$$T_{a,0} T_{a,2} = A_{a,1}^+ \bar{A}_{a,1}^-, \quad (a \geq 2), \quad (\text{C.5})$$

in consistency with (2.11).

The transfer matrices in the horizontal direction $T_{1,s}$ are generated by Bazhanov-Reshetikhin formula [98] (see also [99, 14, 97]):

$$T_{a,s} \equiv \det \begin{pmatrix} T_{a,1}^{[-s+1]} & T_{a-1,1}^{[-s+2]} & \cdots & T_{a+2-s,1}^{[-1]} & T_{a+1-s,1} \\ T_{a+1,1}^{[-s+2]} & T_{a,1}^{[-s+3]} & \cdots & T_{a+3-s,1} & T_{a+2-s,1}^{[+1]} \\ \vdots & \vdots & & \vdots & \vdots \\ T_{a-2+s,1}^{[-1]} & T_{a-3+s,1} & \cdots & T_{a,1}^{[s-3]} & T_{a-1,1}^{[s-2]} \\ T_{a-1+s,1} & T_{a-2+s,1}^{[+1]} & \cdots & T_{a+1,1}^{[s-2]} & T_{a,1}^{[s-1]} \end{pmatrix},$$

$$T_{a,0} = 1, \quad T_{0,s} = 1, \quad T_{a<0,s} = 0. \quad (\text{C.6})$$

Note that the boundary conditions $T_{a,0} = T_{0,s} = 1$ are important in applying this formula. From explicit computation we obtain the following results:

$$T_{1,s} \equiv \Theta_{1,s} \text{TH}_{1,s}, \quad \Theta_{1,s} = (-1)^s \left(\prod_{k=1}^{s-1} \frac{\mathcal{R}_{(+)}^{[-s+2k]}}{\mathcal{R}_{(-)}^{[-s+2k]}} \right), \quad (\text{C.7})$$

$$\text{TH}_{1,s} \equiv (s+1) \frac{\mathcal{R}_{(+)}^{[+s]}}{\mathcal{R}_{(-)}^{[+s]}} - s - s \frac{\mathcal{R}_{(+)}^{[+s]} \mathcal{B}_{(+)}^{[-s]}}{\mathcal{R}_{(-)}^{[+s]} \mathcal{B}_{(-)}^{[-s]}} + (s-1) \frac{\mathcal{B}_{(+)}^{[-s]}}{\mathcal{B}_{(-)}^{[-s]}}, \quad (\text{C.8})$$

for $s \geq 1$. We have $T_{1,0} = 1$ at $s = 0$. The factor $\Theta_{1,s}$ satisfies

$$\Theta_{1,s}^- \Theta_{1,s}^+ = \Theta_{1,s-1} \Theta_{1,s+1}, \quad (s \geq 2), \quad (\text{C.9})$$

²¹Furthermore, for each sum of (C.2) one can solve the recursion, *e.g.* $T_{a,1}^{(B1)+} - A_{a,1}^{(B1)+} = \frac{\bar{A}_{a,1}^{(B1)+}}{A_{a-1,1}^{(B1)}} T_{a-1,1}^{(B1)}$.

and can be regarded as an artifact of our gauge choice.²²

The gauge choice $T_{1,s} = \text{TH}_{1,s}$ is useful to discuss the horizontal strip of $\mathfrak{su}(2|4|2)$ -hook. Note that $\text{TH}_{1,0} \neq 1$ in this gauge. To see this, consider gauge transformation of the T-system at $(1, 1)$,

$$\Theta_{1,1}^- \Theta_{1,1}^+ \text{TH}_{1,1}^- \text{TH}_{1,1}^+ = \Theta_{1,2} \Theta_{1,0} \text{TH}_{1,2} \text{TH}_{1,0} + \Theta_{2,1} \Theta_{0,1} \text{TH}_{2,1} \text{TH}_{0,1}, \quad (\text{C.10})$$

where $\Theta_{1,0} \text{TH}_{1,0} = 1$, because the original transfer matrix satisfies $T_{1,0} = 1$. Gauge-covariance requires

$$1 = \Theta_{1,1}^- \Theta_{1,1}^+ = \Theta_{1,2} \Theta_{1,0} = \Theta_{2,1} \Theta_{0,1}, \quad \Rightarrow \quad \Theta_{1,0} = \frac{1}{\Theta_{1,2}} = \frac{\mathcal{R}_{(-)}}{\mathcal{R}_{(+)}} , \quad (\text{C.11})$$

showing that $\text{TH}_{1,0} = 1/\Theta_{1,0} \neq 1$.

C.2 Asymptotic Wronskian formula

We compare the Wronskian formula (3.1) and the asymptotic transfer matrix $T_{1,s}$ in the $\mathfrak{sl}(2)$ sector to find the asymptotic form of Q-functions. The result should agree with [64] modulo gauge transformation.

We begin with the relation

$$T_{0,s} T_{2,s} = \frac{\mathcal{Q}^{[+s-2]}}{\mathcal{Q}^{[-s+2]}} \frac{\mathcal{R}_{(-)}^{[-s+1]}}{\mathcal{R}_{(+)}^{[-s+1]}} \frac{\mathcal{R}_{(-)}^{[s-1]}}{\mathcal{R}_{(+)}^{[s-1]}} (\Theta_{1,s} A_{s,1})^+ (\Theta_{1,s} \bar{A}_{s,1})^- = L_{1,s}^+ \bar{L}_{1,s}^- . \quad (\text{C.12})$$

There are many ways to define $L_{1,s}$ and $\bar{L}_{1,s}$. We choose the definition such that both $L_{1,s}/\Theta_{1,s}$ and $\bar{L}_{1,s}/\Theta_{1,s}$ are translationally invariant ($X_{1,s} = X_{1,s-1}^+$, $\bar{X}_{1,s} = \bar{X}_{1,s-1}^-$), as

$$\begin{aligned} \frac{L_{1,s}^+}{\Theta_{1,s}^+} &= A_{s,1}^+ = 1 + \frac{\mathcal{R}_{(+)}^{[s+1]}}{\mathcal{R}_{(-)}^{[s+1]}} \frac{\mathcal{R}_{(+)}^{[s-1]}}{\mathcal{R}_{(-)}^{[s-1]}} - 2 \frac{\mathcal{R}_{(+)}^{[s+1]}}{\mathcal{R}_{(-)}^{[s+1]}} , \\ \frac{\bar{L}_{1,s}^-}{\Theta_{1,s}^-} &= \frac{\mathcal{Q}^{[+s-2]}}{\mathcal{Q}^{[-s+2]}} \frac{\mathcal{R}_{(-)}^{[-s+1]}}{\mathcal{R}_{(+)}^{[-s+1]}} \frac{\mathcal{R}_{(-)}^{[s-1]}}{\mathcal{R}_{(+)}^{[s-1]}} \bar{A}_{s,1}^- = 1 + \frac{\mathcal{B}_{(+)}^{[-s-1]}}{\mathcal{B}_{(-)}^{[-s-1]}} \frac{\mathcal{B}_{(+)}^{[-s+1]}}{\mathcal{B}_{(-)}^{[-s+1]}} - 2 \frac{\mathcal{B}_{(+)}^{[-s+1]}}{\mathcal{B}_{(-)}^{[-s+1]}} , \end{aligned} \quad (\text{C.13})$$

where we used the explicit form of A 's (C.4).

We define auxiliary variables $(C_{1,s}, \bar{C}_{1,s})$ by

$$C_{1,s} = \Theta_{1,s} \left(\frac{\mathcal{R}_{(+)}^{[+s]}}{\mathcal{R}_{(-)}^{[+s]}} - 1 \right), \quad \bar{C}_{1,s} = \Theta_{1,s} \left(1 - \frac{\mathcal{B}_{(+)}^{[-s]}}{\mathcal{B}_{(-)}^{[-s]}} \right), \quad (\text{C.14})$$

²²Here $\Theta_{1,s}$ means the gauge transformation from $T_{1,s}$ in (C.6) to $\text{TH}_{1,s}$ in (C.8). In the main text, $\Phi_{1,s}$ means a general gauge transformation.

and $(U_{1,s}, \bar{U}_{1,s})$ by

$$L_{1,s}^+ = \frac{1}{\Theta_{1,s}^-} \det \begin{pmatrix} C_{1,s}^+ & U_{1,s}^+ \\ C_{1,s}^- & U_{1,s}^- \end{pmatrix}, \quad \bar{L}_{1,s}^- = \frac{1}{\Theta_{1,s}^+} \det \begin{pmatrix} \bar{C}_{1,s}^+ & \bar{U}_{1,s}^+ \\ \bar{C}_{1,s}^- & \bar{U}_{1,s}^- \end{pmatrix}. \quad (\text{C.15})$$

The explicit form of $(U_{1,s}, \bar{U}_{1,s})$ can be obtained by solving the difference equations (C.15).

The general solutions of these difference equations are

$$\begin{aligned} U_{1,s} &= -\Theta_{1,s} - \left\{ \frac{g}{2i} \left(v + \frac{is}{g} \right) + F_{1,s} \right\} C_{1,s}, & F_{1,s}^- &= F_{1,s}^+, \\ \bar{U}_{1,s} &= +\Theta_{1,s} - \left\{ \frac{g}{2i} \left(v - \frac{is}{g} \right) + \bar{F}_{1,s} \right\} \bar{C}_{1,s}, & \bar{F}_{1,s}^+ &= \bar{F}_{1,s}^-. \end{aligned} \quad (\text{C.16})$$

We constrain two periodic functions F, \bar{F} by comparing $T_{1,s} = \Theta_{1,s} \text{TH}_{1,s}$ in (C.8) with the Wronskian formula,

$$\text{TH}_{1,s} = \frac{1}{\Theta_{1,s}} (C_{1,s} \bar{U}_{1,s} - \bar{C}_{1,s} U_{1,s}), \quad (\text{C.17})$$

which gives

$$\Psi_{1,s} \equiv F_{1,s} = \bar{F}_{1,s}, \quad \Psi_{1,s}^- = \Psi_{1,s}^+. \quad (\text{C.18})$$

The variable Ψ corresponds to the freedom of superposing two linearly independent solutions $U \rightarrow U + \Psi C$. The Wronskian formulae (C.15), (C.17) do not change as long as $\Psi^+ = \Psi^-$, so we may set $\Psi_{1,s} = 0$. Therefore, the asymptotic formula (C.16) can be summarized as

$$U_{1,s} = -\Theta_{1,s} - \frac{g}{2i} \left(v + \frac{is}{g} \right) C_{1,s}, \quad \bar{U}_{1,s} = +\Theta_{1,s} - \frac{g}{2i} \left(v - \frac{is}{g} \right) \bar{C}_{1,s}. \quad (\text{C.19})$$

Let us relate (C, L, U) and the conjugates to the Q-functions in Section 3.1. We can identify²³

$$\begin{pmatrix} C_{1,s} \\ \bar{C}_{1,s} \\ U_{1,s} \\ \bar{U}_{1,s} \end{pmatrix} \simeq \begin{pmatrix} Q_1^{[+s]} \\ Q_2^{[-s]} \\ Q_2^{[+s]} \\ Q_1^{[-s]} \end{pmatrix} = \begin{pmatrix} Q_{1,s}^{\text{I}} \\ \bar{Q}_{1,s}^{\text{I}} \\ Q_{1,s}^{\text{II}} \\ \bar{Q}_{1,s}^{\text{II}} \end{pmatrix}, \quad \begin{pmatrix} L_{1,s} \\ \bar{L}_{1,s} \end{pmatrix} \simeq \begin{pmatrix} Q_{12}^{[s-1]} \\ Q_{\emptyset}^{[-s+1]} Q_{12}^{[-s+1]} \end{pmatrix}. \quad (\text{C.20})$$

where \simeq means that they are equal up to gauge transformation. One can also check that (C, L, U) and the conjugates solve the difference equations (3.10). The determinant formula (C.15) turns out to be identical to (3.3) if $Q_{\emptyset} = -1$.

²³Such identification of C 's is motivated by the expression of [64]. Note that their definition of $x(v)$ in the mirror region is opposite to ours.

C.3 Analyticity data

We enlist the analyticity data of the asymptotic solution in the $\mathfrak{sl}(2)$ sector. Since the two pairs of fundamental Q -functions $(C_{1,s}, \bar{C}_{1,s})$ and $(U_{1,s}, \bar{U}_{1,s})$ have almost the same analytic structure (like the location of poles and branch cuts), we denote them collectively by $(Q_{1,s}^\alpha, \bar{Q}_{1,s}^\alpha)$.

The location of poles is:

$$\begin{aligned} \text{TH}_{1,s}(v) = \infty & \quad \text{at } v = u_j - \frac{i(s+1)}{g}, \\ L_{1,s}(v) = \infty & \quad \text{at } v = u_j - \frac{i(s-1)}{g}, \\ Q_{1,s}^\alpha(v) = \infty & \quad \text{at } v = u_j - \frac{i(s+1)}{g}. \end{aligned} \quad (\text{C.21})$$

The conjugate variables $\bar{L}_{1,s}, \bar{Q}_{1,s}^\alpha$ are not singular on the top sheet of the complex plane for v . The location of branch cuts is:

$$\begin{aligned} \text{TH}_{1,s}(v+i0) \neq \text{TH}_{1,s}(v-i0) & \quad \text{at } \text{Im } v = \pm \frac{s}{g}, \\ L_{1,s}(v+i0) \neq L_{1,s}(v-i0) & \quad \text{at } \text{Im } v = -\frac{s-2}{g}, -\frac{s}{g}, \\ \bar{L}_{1,s}(v+i0) \neq \bar{L}_{1,s}(v-i0) & \quad \text{at } \text{Im } v = +\frac{s-2}{g}, +\frac{s}{g}, \\ Q_{1,s}^\alpha(v+i0) \neq Q_{1,s}^\alpha(v-i0) & \quad \text{at } \text{Im } v = -\frac{s}{g}, \\ \bar{Q}_{1,s}^\alpha(v+i0) \neq \bar{Q}_{1,s}^\alpha(v-i0) & \quad \text{at } \text{Im } v = +\frac{s}{g}, \end{aligned} \quad (\text{C.22})$$

In the limit $\text{Re } v \rightarrow \pm\infty$, these functions approach a constant. In short, if $s \geq 3$, the quantities (L, Q) are analytic in the upper half plane, whereas (\bar{L}, \bar{Q}) are analytic in the lower half plane. One has to be careful about $(L_{1,2}, Q_{1,1}^-)$ and $(\bar{L}_{1,2}, \bar{Q}_{1,1}^+)$ on the real axis.

As for the variables $(\mathfrak{b}_s^\alpha, \bar{\mathfrak{b}}_s^\alpha)$, we find the branch cuts at:

$$\begin{aligned} \mathfrak{b}_s^\alpha(v+i0) \neq \mathfrak{b}_s^\alpha(v-i0) & \quad \text{at } \text{Im } v = \pm \frac{s-1}{g}, -\frac{s+1}{g}, \\ \bar{\mathfrak{b}}_s^\alpha(v+i0) \neq \bar{\mathfrak{b}}_s^\alpha(v-i0) & \quad \text{at } \text{Im } v = \pm \frac{s-1}{g}, +\frac{s+1}{g}. \end{aligned} \quad (\text{C.23})$$

They do not have poles.

We find extra zeroes for $U_{1,s}, \bar{U}_{1,s}$

$$U_{1,s}(v) = 0 \quad \text{at } v = -\frac{i(r+s)}{g} \quad (r > 0), \quad \bar{U}_{1,s}(v) = 0 \quad \text{at } v = \frac{i(\bar{r}+s)}{g} \quad (\bar{r} > 0), \quad (\text{C.24})$$

and similarly for $(\mathfrak{b}_s^{\text{II}}, \bar{\mathfrak{b}}_s^{\text{II}})$. Both r, \bar{r} are far from the origin already at weak coupling, and they run away from the real axis as g increases. For other functions we do not find extra zeroes, at least in the weak coupling.

References

- [1] J. M. Maldacena, “The Large N limit of superconformal field theories and supergravity,” *Adv. Theor. Math. Phys.* **2** (1998) 231 [*Int. J. Theor. Phys.* **38** (1999) 1113] [arXiv:hep-th/9711200].
- [2] C. N. Yang and C. P. Yang, “Thermodynamics of a One-Dimensional System of Bosons with Repulsive Delta-Function Interaction,” *J. Math. Phys.* **10** (1969) 1115.
- [3] M. Gaudin, “Thermodynamics of the Heisenberg-Ising Ring for $\Delta \geq 1$,” *Phys. Rev. Lett.* **26** (1971) 1301.
- [4] M. Takahashi, “One-Dimensional Hubbard model at finite temperature,” *Prog. Theor. Phys.* **47** (1972) 69.
- [5] A. B. Zamolodchikov, “Thermodynamic Bethe Ansatz in Relativistic Models. Scaling Three State Potts and Lee–Yang Models,” *Nucl. Phys. B* **342** (1990) 695.
- [6] J. Ambjorn, R. A. Janik and C. Kristjansen, “Wrapping interactions and a new source of corrections to the spin-chain/string duality,” *Nucl. Phys. B* **736** (2006) 288 [arXiv:hep-th/0510171].
- [7] G. Arutyunov and S. Frolov, “On String S-matrix, Bound States and TBA,” *JHEP* **0712** (2007) 024 [arXiv:0710.1568 [hep-th]].
- [8] N. Beisert and M. Staudacher, “Long-range $psu(2,2|4)$ Bethe Ansatzes for gauge theory and strings,” *Nucl. Phys. B* **727** (2005) 1 [arXiv:hep-th/0504190].
- [9] N. Beisert, “The $SU(2|2)$ dynamic S-matrix,” *Adv. Theor. Math. Phys.* **12** (2008) 945 [arXiv:hep-th/0511082].
- [10] G. Arutyunov and S. Frolov, “String hypothesis for the $AdS_5 \times S^5$ mirror,” *JHEP* **0903** (2009) 152 [arXiv:0901.1417 [hep-th]].
- [11] D. Bombardelli, D. Fioravanti and R. Tateo, “Thermodynamic Bethe Ansatz for planar AdS/CFT: A Proposal,” *J. Phys. A* **42** (2009) 375401 [arXiv:0902.3930 [hep-th]].

- [12] N. Gromov, V. Kazakov, A. Kozak and P. Vieira, “Exact Spectrum of Anomalous Dimensions of Planar $\mathcal{N} = 4$ Supersymmetric Yang-Mills Theory: TBA and excited states,” *Lett. Math. Phys.* **91** (2010) 265 [arXiv:0902.4458 [hep-th]].
- [13] G. Arutyunov and S. Frolov, “Thermodynamic Bethe Ansatz for the $\text{AdS}_5 \times S^5$ Mirror Model,” *JHEP* **0905** (2009) 068 [arXiv:0903.0141 [hep-th]].
- [14] N. Gromov, V. Kazakov and P. Vieira, “Exact Spectrum of Anomalous Dimensions of Planar $\mathcal{N} = 4$ Supersymmetric Yang-Mills Theory,” *Phys. Rev. Lett.* **103** (2009) 131601 [arXiv:0901.3753 [hep-th]].
- [15] D. Volin, “Quantum integrability and functional equations: Applications to the spectral problem of AdS/CFT and two-dimensional sigma models,” *J. Phys. A* **44** (2011) 124003 [arXiv:1003.4725 [hep-th]].
- [16] D. Volin, “String hypothesis for $gl(n|m)$ spin chains: a particle/hole democracy,” arXiv:1012.3454 [hep-th].
- [17] A. Kuniba, T. Nakanishi and J. Suzuki, “Functional relations in solvable lattice models. 1: Functional relations and representation theory,” *Int. J. Mod. Phys. A* **9** (1994) 5215 [arXiv:hep-th/9309137].
- [18] A. Kuniba, T. Nakanishi and J. Suzuki, “Functional relations in solvable lattice model 2: Applications,” *Int. J. Mod. Phys. A* **9** (1994) 5267 [arXiv:hep-th/9310060].
- [19] N. Gromov, V. Kazakov and Z. Tsuboi, “ $PSU(2, 2|4)$ Character of Quasiclassical AdS/CFT,” *JHEP* **1007** (2010) 097 [arXiv:1002.3981 [hep-th]].
- [20] G. Arutyunov and S. Frolov, “Simplified TBA equations of the $\text{AdS}_5 \times S^5$ mirror model,” *JHEP* **0911** (2009) 019 [arXiv:0907.2647 [hep-th]].
- [21] G. Arutyunov, S. Frolov and R. Suzuki, “Exploring the mirror TBA,” *JHEP* **1005** (2010) 031 [arXiv:0911.2224 [hep-th]].
- [22] A. Cavaglia, D. Fioravanti and R. Tateo, “Extended Y-system for the $\text{AdS}_5/\text{CFT}_4$ correspondence,” *Nucl. Phys. B* **843** (2011) 302 [arXiv:1005.3016 [hep-th]].
- [23] S. Frolov and R. Suzuki, “Temperature quantization from the TBA equations,” *Phys. Lett. B* **679** (2009) 60 [arXiv:0906.0499 [hep-th]].

- [24] A. Klümper and P. A. Pearce, “Conformal weights of RSOS lattice models and their fusion hierarchies,” *Physica A* **183** (1992) 304.
- [25] P. Dorey and R. Tateo, “Excited states by analytic continuation of TBA equations,” *Nucl. Phys. B* **482** (1996) 639 [arXiv:hep-th/9607167].
- [26] P. Dorey and R. Tateo, “Excited states in some simple perturbed conformal field theories,” *Nucl. Phys. B* **515** (1998) 575 [arXiv:hep-th/9706140].
- [27] S. Frolov, talk at “From Sigma Models to Four-dimensional QFT,” in DESY Hamburg, December, 2010. <http://qft2010.desy.de/e88901/>
- [28] N. Gromov, V. Kazakov and P. Vieira, “Exact Spectrum of Planar N=4 Supersymmetric Yang-Mills Theory: Konishi Dimension at Any Coupling,” *Phys. Rev. Lett.* **104** (2010) 211601 [arXiv:0906.4240 [hep-th]].
- [29] S. Frolov, “Konishi operator at intermediate coupling,” *J. Phys. A* **44** (2011) 065401 [arXiv:1006.5032 [hep-th]].
- [30] R. Roiban and A. A. Tseytlin, “Quantum strings in $AdS_5 \times S^5$: Strong-coupling corrections to dimension of Konishi operator,” *JHEP* **0911** (2009) 013 [arXiv:0906.4294 [hep-th]].
- [31] N. Gromov, D. Serban, I. Shenderovich, D. Volin and D. Volin, “Quantum folded string and integrability: From finite size effects to Konishi dimension,” arXiv:1102.1040 [hep-th].
- [32] B. C. Vallilo and L. Mazzucato, “The Konishi multiplet at strong coupling,” arXiv:1102.1219 [hep-th].
- [33] R. Roiban and A. A. Tseytlin, “Semiclassical string computation of strong-coupling corrections to dimensions of operators in Konishi multiplet,” arXiv:1102.1209 [hep-th].
- [34] G. Arutyunov, S. Frolov and R. Suzuki, “Five-loop Konishi from the Mirror TBA,” *JHEP* **1004** (2010) 069 [arXiv:1002.1711 [hep-th]].
- [35] J. Balog and A. Hegedus, “5-loop Konishi from linearized TBA and the XXX magnet,” *JHEP* **1006** (2010) 080 [arXiv:1002.4142 [hep-th]].
- [36] M. Luscher, “Volume Dependence of the Energy Spectrum in Massive Quantum Field Theories. 1. Stable Particle States,” *Commun. Math. Phys.* **104** (1986) 177.
- [37] R. A. Janik and T. Lukowski, “Wrapping interactions at strong coupling: the Giant magnon,” *Phys. Rev. D* **76** (2007) 126008 [arXiv:0708.2208 [hep-th]].

- [38] Z. Bajnok and R. A. Janik, “Four-loop perturbative Konishi from strings and finite size effects for multiparticle states,” Nucl. Phys. B **807** (2009) 625 [arXiv:0807.0399 [hep-th]].
- [39] Z. Bajnok, A. Hegedus, R. A. Janik and T. Lukowski, “Five loop Konishi from AdS/CFT,” Nucl. Phys. B **827** (2010) 426 [arXiv:0906.4062 [hep-th]].
- [40] F. Fiamberti, A. Santambrogio, C. Sieg and D. Zanon, “Wrapping at four loops in $\mathcal{N} = 4$ Sym,” Phys. Lett. B **666** (2008) 100 [arXiv:0712.3522 [hep-th]].
- [41] F. Fiamberti, A. Santambrogio, C. Sieg and D. Zanon, “Anomalous dimension with wrapping at four loops in $\mathcal{N} = 4$ Sym,” Nucl. Phys. B **805** (2008) 231 [arXiv:0806.2095 [hep-th]].
- [42] V. N. Velizhanin, “The four-loop anomalous dimension of the Konishi operator in $\mathcal{N} = 4$ supersymmetric Yang-Mills theory,” JETP Lett. **89** (2009) 6 [arXiv:0808.3832 [hep-th]].
- [43] T. Lukowski, A. Rej and V. N. Velizhanin, “Five-Loop Anomalous Dimension of Twist-Two Operators,” Nucl. Phys. B **831** (2010) 105 [arXiv:0912.1624 [hep-th]].
- [44] J. Balog and A. Hegedus, “The Bajnok-Janik formula and wrapping corrections,” JHEP **1009** (2010) 107 [arXiv:1003.4303 [hep-th]].
- [45] A. N. Kirillov and N. Y. Reshetikhin, “Representations of Yangians and multiplicities of the inclusion of the irreducible components of the tensor product of representations of simple Lie algebras, J. Soviet Math. **52** (1990) 3156.
- [46] N. Gromov, “Y-system and Quasi-Classical Strings,” JHEP **1001** (2010) 112 [arXiv:0910.3608 [hep-th]].
- [47] N. Gromov and F. Levkovich-Maslyuk, “Y-system and β -deformed $\mathcal{N} = 4$ Super-Yang-Mills,” J. Phys. A **44** (2011) 015402 [arXiv:1006.5438 [hep-th]].
- [48] G. Arutyunov, M. de Leeuw and S. J. van Tongeren, “Twisting the Mirror TBA,” JHEP **1102** (2011) 025 [arXiv:1009.4118 [hep-th]].
- [49] C. Ahn, Z. Bajnok, D. Bombardelli and R. I. Nepomechie, “Twisted Bethe equations from a twisted S-matrix,” JHEP **1102** (2011) 027 [arXiv:1010.3229 [hep-th]].
- [50] M. de Leeuw and T. Lukowski, “Twist operators in $\mathcal{N} = 4$ beta-deformed theory,” arXiv:1012.3725 [hep-th].
- [51] M. Beccaria, F. Levkovich-Maslyuk and G. Macorini, “On wrapping corrections to GKP-like operators,” JHEP **1103** (2011) 001 [arXiv:1012.2054 [hep-th]].

- [52] A. Klümper, M. T. Batchelor, “An analytic treatment of finite-size corrections in the spin-1 antiferromagnetic XXZ chain,” *J. Phys. A* **23** (1990) L189.
- [53] A. Klümper, M. T. Batchelor and P. A. Pearce, “Central charges of the 6- and 19- vertex models with twisted boundary conditions,” *J. Phys. A* **24** (1991) 3111.
- [54] C. Destri and H. J. de Vega, “New approach to thermal Bethe ansatz,” arXiv:hep-th/9203064.
- [55] C. Destri and H. J. de Vega, “New thermodynamic Bethe ansatz equations without strings,” *Phys. Rev. Lett.* **69** (1992) 2313.
- [56] V. V. Bazhanov, S. L. Lukyanov and A. B. Zamolodchikov, “Integrable structure of conformal field theory. 2. Q operator and Ddv equation,” *Commun. Math. Phys.* **190** (1997) 247 [arXiv:hep-th/9604044].
- [57] M. Takahashi, “Simplification of Thermodynamic Bethe-Ansatz Equations,” *Physics and Combinatorics 2000* (Proceedings of the Nagoya 2000 International Workshop on Physics and Combinatorics, Nagoya University, August 21-26, 2000, eds. A. N. Kirillov and N. Liskova, World Scientific, Singapore), (2001) 299, [cond-mat/0010486].
- [58] M. Takahashi, M. Shiroishi and A. Klümper, “Equivalence of TBA and QTM,” *J. Phys. A* **34** (2001) L187-L194, [cond-mat/0102027].
- [59] R. J. Baxter, “Partition function of the eight-vertex lattice model, *Annals Phys.* **70** (1972) 193, *Annals Phys.* **281** (2000) 187.
- [60] I. Krichever, O. Lipan, P. Wiegmann and A. Zabrodin, “Quantum integrable systems and elliptic solutions of classical discrete nonlinear equations,” *Commun. Math. Phys.* **188** (1997) 267 [arXiv:hep-th/9604080].
- [61] V. Kazakov, A. S. Sorin and A. Zabrodin, “Supersymmetric Bethe ansatz and Baxter equations from discrete Hirota dynamics,” *Nucl. Phys. B* **790** (2008) 345 [arXiv:hep-th/0703147].
- [62] A. Hegedus, “Discrete Hirota dynamics for AdS/CFT,” *Nucl. Phys. B* **825** (2010) 341 [arXiv:0906.2546 [hep-th]].
- [63] Z. Tsuboi, “Solutions of the T-system and Baxter equations for supersymmetric spin chains,” *Nucl. Phys. B* **826** (2010) 399 [arXiv:0906.2039 [math-ph]].

- [64] N. Gromov, V. Kazakov, S. Leurent and Z. Tsuboi, “Wronskian Solution for AdS/CFT Y-system,” JHEP **1101** (2011) 155 [arXiv:1010.2720 [hep-th]].
- [65] J. Suzuki, “Spinons in magnetic chains of arbitrary spins at finite temperatures,” J. Phys. A **32**, (1999) 2341, [cond-mat/9807076].
- [66] N. Yu Reshetikhin, “S-matrices in integrable models of isotropic magnetic chains. I,” J. Phys. A **24** (1991) 3299.
- [67] D. 2. Bernard, V. Pasquier and D. Serban, “Spinons in conformal field theory,” Nucl. Phys. B **428** (1994) 612 [arXiv:hep-th/9404050].
- [68] J. Suzuki, “Characters for $\widehat{\mathfrak{sl}(n)}_{k=1}$ from a novel thermodynamic Bethe ansatz,” J. Phys. A **31**, (1998) 6887, [cond-mat/9805242].
- [69] A. Hegedus, “Finite size effects in the Ss model: Two component nonlinear integral equations,” Nucl. Phys. B **679** (2004) 545 [arXiv:hep-th/0310051].
- [70] N. Gromov, V. Kazakov and P. Vieira, “Finite Volume Spectrum of 2D Field Theories from Hirota Dynamics,” JHEP **0912** (2009) 060 [arXiv:0812.5091 [hep-th]].
- [71] J. Caetano, “Unified approach to the $SU(2)$ Principal Chiral Field model at Finite Volume,” arXiv:1012.2600 [hep-th].
- [72] C. Destri and H. J. De Vega, “Unified approach to thermodynamic Bethe Ansatz and finite size corrections for lattice models and field theories,” Nucl. Phys. B **438** (1995) 413 [arXiv:hep-th/9407117].
- [73] D. Fioravanti, A. Mariottini, E. Quattrini and F. Ravanini, “Excited state Destri-De Vega equation for Sine-Gordon and restricted Sine-Gordon models,” Phys. Lett. B **390** (1997) 243 [arXiv:hep-th/9608091].
- [74] G. Feverati, F. Ravanini and G. Takacs, “Nonlinear integral equation and finite volume spectrum of Sine-Gordon theory,” Nucl. Phys. B **540** (1999) 543 [arXiv:hep-th/9805117].
- [75] A. Klümper, “Thermodynamics of the anisotropic spin-1/2 Heisenberg chain and related quantum chains,” Z. Phys. B **91** (1993) 507, [cond-mat/9306019].
- [76] A. Klümper, T. Wehner and J. Zittartz, “Conformal spectrum of the six-vertex model,” J. Phys. A **26** (1993), 2815.

- [77] A. Klümper, “Free energy and correlation lengths of quantum chains related to restricted solid-on-solid lattice models.” *Ann. Phys.* **1** (1992) 540.
- [78] J. Balog and A. Hegedus, “The finite size spectrum of the 2-dimensional $O(3)$ nonlinear sigma-model,” *Nucl. Phys. B* **829** (2010) 425 [arXiv:0907.1759 [hep-th]].
- [79] M. Suzuki, “Transfer-matrix method and Monte Carlo simulation in quantum spin systems,” *Phys. Rev. B* **31** (1985) 2957.
- [80] F. H. L. Essler, H. Frahm, F. Göhmann, A. Klümper and V. E. Korepin, “The one-dimensional Hubbard model, Cambridge University Press (2005).
- [81] A. .N. Kirillov and N. Yu Reshetikhin, “Exact solution of the integrable XXZ Heisenberg model with arbitrary spin: I. the ground state and the excitation spectrum,” *J. Phys. A* **20** (1987) 1587.
- [82] G. P. Pronko and Yu. G. Stroganov, “Bethe equations ‘on the wrong side of equator’,” *J. Phys. A* **32** (1999) 2333 [arXiv:hep-th/9808153].
- [83] G. P. Pronko, “On the Baxter’s Q operator for the X X X spin chain,” *Commun. Math. Phys.* **212** (2000) 687 [arXiv:hep-th/9908179].
- [84] V. V. Bazhanov, T. Lukowski, C. Meneghelli and M. Staudacher, “A Shortcut to the Q-Operator,” *J. Stat. Mech.* **1011** (2010) P11002 [arXiv:1005.3261 [hep-th]].
- [85] J. Damerau and A. Klumper, “Non-linear integral equations for the thermodynamics of the $sl(4)$ -symmetric Uimin-Sutherland model,” *J. Stat. Mech.* **0612** (2006) P12014 [arXiv:cond-mat/0610559].
- [86] J. Damerau, “Nonlinear Integral Equations for the Thermodynamics of Integrable Quantum Chains,” Dissertation at Universität Wuppertal, 2010.
<http://elpub.bib.uni-wuppertal.de/servlets/DocumentServlet?id=900>
- [87] L. D. Faddeev and N. Y. Reshetikhin, “Integrability of the Principal Chiral Field Model in (1+1)-DIMENSION,” *Annals Phys.* **167** (1986) 227.
- [88] C. Destri and H. J. de Vega, “Light Cone Lattice Approach to Fermionic Theories in 2-D: the Massive Thirring Model,” *Nucl. Phys. B* **290** (1987) 363.
- [89] H. Boos, M. Jimbo, T. Miwa, F. Smirnov and Y. Takeyama, “Hidden Grassmann structure in the Xxz model,” *Commun. Math. Phys.* **272** (2007) 263 [arXiv:hep-th/0606280].

- [90] H. Boos, M. Jimbo, T. Miwa, F. Smirnov and Y. Takeyama, “Hidden Grassmann Structure in the Xxz Model II: Creation Operators,” *Commun. Math. Phys.* **286** (2009) 875 [arXiv:0801.1176 [hep-th]].
- [91] M. Jimbo, T. Miwa and F. Smirnov, “Hidden Grassmann Structure in the Xxz Model III: Introducing Matsubara direction,” *J. Phys. A* **42** (2009) 304018 [arXiv:0811.0439 [math-ph]].
- [92] H. Boos, M. Jimbo, T. Miwa and F. Smirnov, “Hidden Grassmann Structure in the Xxz Model IV: CFT limit,” *Commun. Math. Phys.* **299** (2010) 825 [arXiv:0911.3731 [hep-th]].
- [93] M. Jimbo, T. Miwa and F. Smirnov, “Hidden Grassmann structure in the Xxz model V: Sine-Gordon model,” arXiv:1007.0556 [hep-th].
- [94] N. Gromov (presented by V. Kazakov), talk at “Conference on Integrability in Gauge and String Theory 2010,” in Nordita Stockholm, June, 2010. <http://agenda.albanova.se/contributionDisplay.py?contribId=258&confId=1561>
- [95] N. Gromov, V. Kazakov, S. Leurent and D. Volin, “Solving the AdS/CFT Y-System,” arXiv:1110.0562 [hep-th].
- [96] A. Klümper, talk at “Workshop on Integrable Quantum Systems,” in Dublin Institute for Advanced Studies, December, 2008. http://www.stp.dias.ie/events/2008/DIAS_Integrability.shtml
- [97] G. Arutyunov, M. de Leeuw, R. Suzuki and A. Torrielli, “Bound State Transfer Matrix for $AdS_5 \times S^5$ Superstring,” *JHEP* **0910** (2009) 025 [arXiv:0906.4783 [hep-th]].
- [98] V. Bazhanov and N. Reshetikhin, “Restricted Solid on Solid Models Connected with Simply Based Algebras and Conformal Field Theory,” *J. Phys. A* **23** (1990) 1477.
- [99] N. Beisert, “The Analytic Bethe Ansatz for a Chain with Centrally Extended $su(2-2)$ Symmetry,” *J. Stat. Mech.* **0701** (2007) P01017 [arXiv:nlin/0610017].