

# MORPHISMS BETWEEN INDECOMPOSABLE COMPLEXES IN THE BOUNDED DERIVED CATEGORY OF A GENTLE ALGEBRA

KRISTIN KROGH ARNESEN, ROSANNA LAKING, AND DAVID PAUKSZTELLO

ABSTRACT. In this article we provide a simple combinatorial description of morphisms between indecomposable complexes in the bounded derived category of a gentle algebra.

## CONTENTS

1. Preliminaries and notation	3
2. Indecomposable objects in $D$	4
3. Morphisms between indecomposable objects of $D$	8
4. Proof of the main theorem	12
5. Higher-dimensional band complexes	17
6. Application: Irreducible morphisms between string complexes	24
7. Application: Discrete derived categories	31
References	33

## INTRODUCTION

Triangulated categories are of central importance in many branches of mathematics, providing a common framework for algebraists, geometers, topologists and theoretical physicists, amongst others. Perhaps the most famous illustration of their utility is Beilinson's equivalences between the derived categories of coherent sheaves on projective spaces and representations of certain finite-dimensional algebras [7], which provided deep connections between algebra and geometry.

In algebra and geometry, the triangulated categories we have in mind are derived categories and categories constructed from them, for example, cluster categories. However, despite their utility, there is a major drawback: the construction of derived categories is abstract and explicit computation is often difficult. Indeed, much intuition is often obtained from examples of homological dimension one (= hereditary), owing to particularly nice homological properties which allow one to reduce computations to the (well-understood) abelian categories with which one starts.

Developing intuition in such an abstract setting requires a good collection of examples, for which computation becomes straightforward and non-trivial phenomena can be observed concretely. In this article, we shall show that so-called *gentle algebras* provide a wide class of such examples. Moreover, given their central place in the current thrust of research in cluster-tilting theory, where they occur as surface algebras [3], concrete understanding of the derived categories of gentle algebras is both useful and timely.

---

2010 *Mathematics Subject Classification.* 18E30, 16G10, 05E10.

*Key words and phrases.* bounded derived category, gentle algebra, homotopy string and band, string combinatorics, morphism.

*Main results.* A principal way in which one can understand the structure of a category is, firstly, to describe all its indecomposable objects and, secondly, the morphisms between them. This is demonstrated very successfully by Auslander–Reiten (AR) theory.

Let  $\Lambda$  be a gentle algebra and let  $\mathcal{D}^b(\Lambda)$  be its bounded derived category with shift functor  $\Sigma$ . The first step was accomplished by Bekkert and Merklen in [8] who, inspired by a classic paper [15], described the indecomposable objects of  $\mathcal{D}^b(\Lambda)$  by string combinatorics: these include, in the terminology of [9], the so-called *homotopy string complexes* and (one-dimensional) *homotopy band complexes*, i.e. complexes which can be unfolded to look like an oriented copy of a Dynkin diagram of type  $A$  or type  $\tilde{A}$ , respectively, and whose differentials are paths in the quiver of  $\Lambda$ . Thus, a homotopy string or band is none other than a word whose letters consist of paths in the quiver of  $\Lambda$  and their inverses.

In this article, we describe all morphisms between indecomposable complexes in  $\mathcal{D}^b(\Lambda)$ , thus completing the hands-on combinatorial framework that facilitates straightforward computation in these non-trivial categories. The main theorem is as follows.

**Theorem A.** *Let  $X$  and  $Y$  be homotopy string or one-dimensional band complexes in  $\mathcal{D}^b(\Lambda)$ . Let  $w_X$  and  $w_Y$  be the words corresponding to  $X$  and  $Y$ . There is a canonical basis of  $\text{Hom}_{\mathcal{D}^b(\Lambda)}(X, Y)$  given by the following three classes of maps:*

- **graph maps:** *corresponding to the maximal overlaps in  $w_X$  and  $w_Y$  satisfying certain compatibility conditions at the endpoints.*
- **quasi-graph maps:** *corresponding to maximal overlaps in  $w_X$  and  $w_{\Sigma^{-1}Y}$  satisfying certain non-degeneracy conditions at the endpoints; these give rise to homotopy classes of maps  $X \rightarrow Y$ .*
- **singleton maps:** *certain special maps which can be detected easily from the word combinatorics of  $w_X$  and  $w_Y$ .*

The remaining indecomposable complexes in  $\mathcal{D}^b(\Lambda)$  are constructed from homotopy band complexes. Homotopy band complexes sit at the mouths of homogeneous tubes: a tube is indexed by a homotopy band and a non-zero scalar. The object of length  $n$  in a given tube is specified by the additional data of an  $n$ -dimensional vector space. We call these ‘higher-dimensional’ band complexes; we refer to Section 5 for more precise details. Theorem A deals with one-dimensional band complexes and string complexes, which are always ‘one-dimensional’. What about maps involving higher dimensional band complexes? Our second main theorem tells us that we don’t have to worry about them:

**Theorem B.** *Suppose  $X$  and  $Y$  are string or one-dimensional band complexes in  $\mathcal{D}^b(\Lambda)$ . For  $X$  a homotopy band, let  $X_n$  be its ‘ $n$ -dimensional’ version, otherwise take  $n = 1$  and  $X_1 = X$ ; similarly for  $Y$ . Then, generically,  $\dim \text{Hom}(X_m, Y_n) = mn \cdot \dim \text{Hom}(X, Y)$ .*

In Theorem B care must be taken when  $X \cong Y$  or  $X \cong \Sigma^{-1}Y$ ; see Section 5 for precise details. The module category analogues of these results are classical; see [16, 17, 20].

In summary: Theorems A and B reduce some difficult homological algebra to elementary word combinatorics. Combined with the description of indecomposables, this opens up a wide and natural class of examples of triangulated categories to explicit computation.

*Applications and context.* Before continuing, we make some remarks on the potential applications of these results. Gentle algebras present us with particularly good candidates to begin a systematic ‘hands on’ study of derived categories for a number of reasons:

- Certain general aspects of the structure of  $\mathcal{D}^b(\Lambda)$  are already known: for instance, the Avella Alaminos–Geiß invariant describes certain fractionally Calabi-Yau triangulated subcategories whose AR components have a boundary [5].

- The AR theory of  $D^b(\Lambda)$  can be computed: using the Happel functor  $F: D^b(\Lambda) \hookrightarrow \underline{\text{mod}}(\hat{\Lambda})$  [18], where  $\hat{\Lambda}$  is the repetitive algebra of  $\Lambda$ , Bobiński [9] gave an algorithm which computes the AR triangles in  $D^b(\Lambda)$ . Indeed, as an application of our results, we recover Bobiński's algorithm without recourse to the Happel functor, and the often unpleasant computations that ensue. Examples of the kinds of results we have in mind are the structural results on the AR quiver in [1, 2], which use the combinatorial invariants of [6] to parametrise the AR components completely. Can one use these to extend the results of Avella Alaminos and Geiß to get better derived invariants?
- Vossieck [21] introduced the family of *derived-discrete algebras*, for which we now understand various non-trivial homological properties [10, 11, 12, 13, 14]. These algebras are gentle, and thus they can be used as a template for further study of derived categories of gentle algebras. Here as an application of our results, we recover the universal Hom-dimension bound of [13].

We expect our results to be useful in the classification of tilting and, more generally, siltling objects for gentle algebras, particularly for surface algebras; such objects are very closely related to cluster-tilting objects. We therefore expect that the string combinatorics here will be adapted to the cluster combinatorics.

Note also that string combinatorics seem not to be confined to representation theory and cluster theory: such combinatorics occur in the setting of homological mirror symmetry. For example, analogous descriptions of indecomposables in categories occurring in this context were presented by R. Bocklandt in the talk 'From A to B via SYZ' at the workshop 'Homological Interactions between Representation Theory and Singularity Theory' held in Edinburgh in December 2014.

**Acknowledgments.** We would like to thank Peter Jørgensen and Mike Prest for valuable comments. KA and DP gratefully acknowledge financial support of the EPSRC through grant EP/K022490/1, and KA would like to thank The University of Manchester for the kind hospitality during two research visits. RL and DP also acknowledge the kind hospitality of the Algebra Group at the Norwegian University of Science and Technology in Trondheim, and for financial support on a research visit there.

## 1. PRELIMINARIES AND NOTATION

Let  $\Gamma = (\Gamma_0, \Gamma_1)$  be a finite connected quiver. Recall from [4] that a bound path algebra  $\Lambda \cong \mathbf{k}\Gamma/I$  is called *gentle* if:

- (1) for each vertex  $x$  of  $\Gamma$ , there are at most two arrows starting at  $x$  and at most two arrows ending at  $x$ ;
- (2) for any arrow  $a$  in  $\Gamma$  there is at most one arrow  $b$  in  $\Gamma$  such that  $ab \notin I$  and at most one arrow  $c$  in  $\Gamma$  such that  $ca \notin I$ ;
- (3) for any arrow  $a$  in  $\Gamma$  there is at most one arrow  $b$  in  $\Gamma$  such that  $ab \in I$  and at most one arrow  $c$  in  $\Gamma$  such that  $ca \in I$ ;
- (4) the ideal  $I$  is generated by paths of length 2.

Let  $P(x)$  be the indecomposable projective left  $\Lambda$ -module corresponding to  $x \in \Gamma_0$ . We recall the following useful property of gentle algebras; see, for instance [8, Section 3].

**Proposition 1.1.** *There is a bijection*

$$\begin{aligned} \{\text{paths } p: x \rightsquigarrow y \text{ in } \Gamma\} &\xleftrightarrow{1-1} \{\text{basis elements of } \text{Hom}_\Lambda(P(y), P(x))\}; \\ p &\longmapsto (u \mapsto up). \end{aligned}$$

**Convention 1.2.** From now on, by abuse of notation, we shall identify a path  $p: x \rightsquigarrow y$  with its corresponding basis element in  $\text{Hom}_\Lambda(P(y), P(x))$ .

Throughout this article, we shall fix a gentle algebra  $\Lambda = \mathbf{k}\Gamma/I$  over an algebraically closed field  $\mathbf{k}$ . Algebraic closure of  $\mathbf{k}$  is not strictly necessary, but it significantly simplifies the presentation of the combinatorics.

All modules in this paper will be left modules. We shall be interested in three categories:

- $\mathcal{C} := \mathcal{C}^{-,b}(\text{proj}(\Lambda))$ : the category of right bounded complexes of finitely generated projective  $\Lambda$ -modules whose cohomology is bounded;
- $\mathcal{K} := \mathcal{K}^b(\text{proj}(\Lambda))$ : the homotopy category of bounded complexes of finitely generated projective  $\Lambda$ -modules – the so-called *perfect complexes*;
- $\mathcal{D} := \mathcal{D}^b(\Lambda) = \mathcal{D}^b(\text{mod}(\Lambda))$ : the bounded derived category of finitely generated  $\Lambda$ -modules.

Throughout the paper, we shall identify the bounded derived category  $\mathcal{D}$  with the triangle equivalent category  $\mathcal{K}^{-,b}(\text{proj}(\Lambda))$ , consisting of right bounded complexes of finitely generated projective  $\Lambda$ -modules whose cohomology is bounded. This identification allows us to use the combinatorics of homotopy strings and bands, which will be described in the next section, throughout the paper. We direct the reader to consult [18] for background on derived and homotopy categories.

## 2. INDECOMPOSABLE OBJECTS IN $\mathcal{D}$

In this section we give an overview of Bekkert and Merklen’s description of the indecomposable objects in  $\mathcal{D}$ . Their crucial observation is that it is enough to consider complexes where the differential is given by matrices whose entries are either zero or a path (cf. Convention 1.2). The indecomposable objects are obtained by unravelling the differential into ‘homotopy strings and bands’ corresponding to perfect complexes, and ‘infinite homotopy strings’ for the unbounded complexes. The reader is encouraged to have the following example in mind when reading this section:

**Running Example.** Let  $\Lambda = \mathbf{k}\Gamma/I$  be given by the quiver

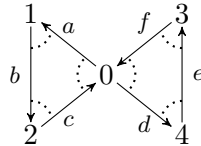

The following complex, with the leftmost non-zero term in cohomological degree 0, is an indecomposable object of  $\mathcal{K}$ :

$$0 \longrightarrow P(0) \xrightarrow{(c \ f)} P(2) \oplus P(3) \xrightarrow{\begin{pmatrix} b & 0 \\ 0 & e \end{pmatrix}} P(1) \oplus P(4) \xrightarrow{\begin{pmatrix} a & f \\ 0 & 0 \end{pmatrix}} P(3) \longrightarrow 0.$$

Observe that the criterion  $d^2 = 0$  is obtained by either passing through a relation, or by having 0 in the differential. We notice that this complex ‘unfolds’ as

$$\begin{array}{cccccc} 2 & & 1 & & 0 & & 1 & & 2 & & 3 \\ P(4) & \xleftarrow{e} & P(3) & \xleftarrow{f} & P(0) & \xrightarrow{c} & P(2) & \xrightarrow{b} & P(1) & \xrightarrow{af} & P(3) \end{array}$$

where the cohomological degrees are written above each module. Moreover, the modules appearing are uniquely determined by the endpoints of the maps, so all information in

this complex is communicated by the diagram

$$\begin{array}{ccccccc} 2 & & 1 & & 0 & & 1 & & 2 & & 3 \\ \bullet & \xleftarrow{e} & \bullet & \xleftarrow{f} & \bullet & \xrightarrow{c} & \bullet & \xrightarrow{b} & \bullet & \xrightarrow{af} & \bullet \end{array}$$

This is what we will later define as a ‘homotopy string’. Another way of encoding this object is as a ‘string with degrees’  $(e, 2, 1)(f, 1, 0)(c, 0, 1)(b, 1, 2)(af, 2, 3)$ .

**Remark 2.1.** By using transposed matrices, matrix multiplication (i.e. composing maps) fits with composition of paths. For instance;  $(cf) \begin{pmatrix} b & 0 \\ 0 & e \end{pmatrix} = (cbfe) = 0$ .

**2.1. Homotopy strings.** A *homotopy letter* is a triple  $(p, i, j)$  where  $p$  is a path in  $\Gamma$  with no subpath in  $I$ , and  $i, j$  are integers such that  $|i - j| \leq 1$ . The homotopy letter  $(p, i, j)$  is called *direct* if  $i < j$  and *inverse* if  $i > j$ . If  $i = j$  then  $p$  must be a stationary path and is called a *trivial* homotopy letter. We set  $(p, i, j)^{-1} := (p, j, i)$ . The starting and ending vertices of a homotopy letter are defined as

$$s(p, i, j) = \begin{cases} t(p) & \text{if } (p, i, j) \text{ is inverse;} \\ s(p) & \text{otherwise;} \end{cases} \quad \text{and} \quad t(p, i, j) = \begin{cases} s(p) & \text{if } (p, i, j) \text{ is inverse;} \\ t(p) & \text{otherwise.} \end{cases}$$

The composition  $(p, i, j)(p', i', j')$  is defined if  $j = i'$  and  $s(p, i, j) = t(p', i', j')$ . If  $(p, i, j)$  is trivial in this situation, we write  $(p, i, j)(p', i', j') := (p', i', j')$ ; similarly if  $(p', i', j')$  is trivial then  $(p, i, j)(p', i', j') := (p, i, j)$ .

**Convention 2.2.** We shall often write  $p$  as shorthand for  $(p, i, j)$ . However, the degrees  $i, j$  should always be considered to be implicitly present.

A *homotopy string* is a sequence of pairwise composable homotopy letters

$$w = \prod_{r=n}^1 (w_r, i_r, j_r) = (w_n, i_n, j_n)(w_{n-1}, i_{n-1}, j_{n-1}) \cdots (w_2, i_2, j_2)(w_1, i_1, j_1)$$

such that the following holds:

- (1) whenever  $(w_r, i, i + 1)(w_{r-1}, i + 1, i + 2)$  occurs,  $w_r w_{r-1}$  has a subpath in  $I$ ;
- (2) whenever  $(w_r, i, i - 1)(w_{r-1}, i - 1, i - 2)$  occurs,  $w_{r-1} w_r$  has a subpath in  $I$ ;
- (3) whenever  $(w_r, i, i + 1)(w_{r-1}, i + 1, i)$  occurs,  $w_r$  and  $w_{r-1}$  do not start with the same arrow;
- (4) whenever  $(w_r, i, i - 1)(w_{r-1}, i - 1, i)$  occurs,  $w_r$  and  $w_{r-1}$  do not end with the same arrow.

Write  $s(w) = s(w_1, i_1, j_1)$  and  $t(w) = t(w_n, i_n, j_n)$  if  $w$  is non-trivial, and for a trivial homotopy string  $w = (1_x, i, i)$  we write  $s(w) = x = t(w)$ . Its inverse is given by

$$((w_n, i_n, j_n) \cdots (w_1, i_1, j_1))^{-1} := (w_1, j_1, i_1) \cdots (w_n, j_n, i_n).$$

Another way of expressing a homotopy string  $w = \prod_{r=n}^1 (w_r, i_r, j_r)$  is by a diagram

$$\begin{array}{ccccccc} i_n & & j_n & & & & j_2 & & j_1 \\ \bullet & \xrightarrow{w_n} & \bullet & \xrightarrow{\quad \quad \quad} & \cdots & \xrightarrow{\quad \quad \quad} & \bullet & \xrightarrow{w_1} & \bullet \end{array}$$

where the line labelled  $w_r$  is an arrow pointing to the right if  $w_r$  is direct, and an arrow pointing to the left if  $w_r$  is inverse. Note that each vertex  $\xrightarrow{w_r} \bullet \xrightarrow{w_{r-1}}$  corresponds to a unique indecomposable projective  $\Lambda$ -module, namely  $P(s(w_r)) = P(t(w_{r-1}))$ .



**2.3. Infinite homotopy strings.** These indecomposable complexes only occur when  $\Lambda$  has infinite global dimension: when the global dimension of  $\Lambda$  is finite all the complexes in  $\mathbf{D}$  are isomorphic to perfect complexes. If  $\Lambda = \mathbf{k}\Gamma/I$  has infinite global dimension, then  $\Gamma$  contains oriented cycles with ‘full relations’. Let  $\mathcal{C}(\Lambda)$  denote the collection of arrows  $a \in \Gamma_1$  such that there exists a repetition-free cyclic path  $a_n \cdots a_2 a_1$  in  $\Gamma$  such that  $a_{i+1} a_i \in I$  for  $1 \leq i \leq n$  and  $a_1 a_n \in I$ , where  $a_1 = a$ . We need the following definition from [9].

**Definition 2.5.** A *direct (resp. inverse) antipath* is a homotopy string where all homotopy letters are direct (resp. inverse) and arrows in the quiver.

**Definition 2.6.** Let  $w = \prod_{k=n}^1 (w_k, i_k, j_k)$  be a homotopy string. We say  $w$  is

- (1) *left resolvable* if  $(w_n, i_n, j_n)$  is direct (i.e.  $j_n = i_n + 1$ ),  $i_n \leq i_k, j_k$  for all  $1 \leq k < n$ , and there exists  $a \in \mathcal{C}(\Lambda)$  such that  $(a, i_n - 1, i_n)w$  is a homotopy string. We shall say that  $w$  is *left resolvable by  $a$* .
- (2) *primitive left resolvable* if there is no direct antipath  $\prod_{k=n}^t (w_k, i_k, j_k)$  such that  $\prod_{k=t-1}^1 (w_k, i_k, j_k)$  is left resolvable.

One can write down the obvious dual definitions of *(primitive) right resolvable*. A homotopy string will be called *(primitive) two-sided resolvable* if it is both (primitive) left resolvable and (primitive) right resolvable.

If  $w$  is left (resp. right) resolvable by  $a$ , then gentleness of  $\Lambda$  ensures that this is the unique arrow in  $\Gamma_1$  by which  $w$  is left (resp. right) resolvable. If  $w$  is left resolvable then  $w^{-1}$  is right resolvable, and vice versa. We shall call a left or right resolvable homotopy string that is not two-sided resolvable *one-sided resolvable*. There is then the obvious notion of *primitive one-sided resolvable*.

Suppose  $w = \prod_{k=n}^1 (w_k, i_k, j_k)$  is left resolvable by  $a_1 \in \mathcal{C}(\Lambda)$ , which sits in the repetition-free cyclic path  $a_m \cdots a_1$  in  $\Gamma$ . We form the *left infinite homotopy string*  ${}^\infty w$  by concatenating infinitely many appropriately shifted copies of the cycle on the left of  $w$ , i.e. the unfolded diagram of  ${}^\infty w$  has the form

$${}^\infty w: \quad \cdots \xrightarrow{a_1} \bullet \xrightarrow{a_m} \bullet \cdots \bullet \xrightarrow{a_2} \bullet \xrightarrow{a_1} \bullet \xrightarrow{w_n} \bullet \xrightarrow{w_{n-1}} \bullet \cdots \bullet \xrightarrow{w_1} \bullet \cdots$$

Analogously, we form the *right infinite homotopy string*  $w^\infty$  and the *two-sided infinite homotopy strings*  ${}^\infty w^\infty$  from a right resolvable homotopy string or two-sided resolvable homotopy string, respectively.

If  $w$  is one-sided left resolvable we obtain the corresponding infinite string complex from the left infinite homotopy string  ${}^\infty w$ , or equivalently the right infinite homotopy string  $(w^{-1})^\infty$ . Dually for  $w$  right resolvable. For  $w$  two-sided resolvable we represent it by  ${}^\infty w^\infty$  and  ${}^\infty (w^{-1})^\infty$ .

**2.4. The indecomposable objects of  $\mathbf{D}$ .** We first set up some notation. A *cyclic rotation* of the homotopy band  $w$  is a homotopy band of the form

$$(w_k, i_k, j_k)(w_{k-1}, i_{k-1}, j_{k-1}) \cdots (w_1, i_1, j_1)(w_n, i_n, j_n) \cdots (w_{k+1}, i_{k+1}, j_{k+1}).$$

Consider the equivalence relation  $\sim^{-1}$  generated by identifying a homotopy string with its inverse, and the equivalence relation  $\sim^r$  generated by identifying a homotopy band with its cyclic rotations and their inverses. The following will denote complete sets of

representatives of the specified objects under the given equivalence relations:

$\text{St} :=$  all homotopy strings under  $\sim^{-1}$ ;

$\text{Ba} :=$  all homotopy bands under  $\sim^r$ ;

$\text{St}_1 :=$  all primitive one-sided resolvable homotopy strings under  $\sim^{-1}$ ;

$\text{St}_2 :=$  all primitive two-sided resolvable homotopy strings under  $\sim^{-1}$ .

**Theorem 2.7** ([8, Theorem 3]). *There are bijections*

$$\text{ind}(\mathbf{K}) \xleftrightarrow{1-1} \text{St} \sqcup (\text{Ba} \times \mathbf{k}^* \times \mathbb{N}) \quad \text{and} \quad \text{ind}(\mathbf{D} \setminus \mathbf{K}) \xleftrightarrow{1-1} \text{St}_1 \cup \text{St}_2.$$

We mention here that a homotopy band can always be considered as a homotopy string, thus we must take the disjoint union: a band gives rise both to a string complex and a family of band complexes.

### 3. MORPHISMS BETWEEN INDECOMPOSABLE OBJECTS OF $\mathbf{D}$

In this section, we shall describe a canonical basis for the set of homomorphisms between (finite or infinite) string and/or one-dimensional band complexes; higher dimensional bands are dealt with in Section 5. The proof that the maps described here do indeed form a basis is contained in Section 4.

We first set up some notation and define three canonical classes of maps. Fix  $w \in \text{St} \sqcup \text{Ba}$  and  $\lambda_w \in \mathbf{k}^*$ . Define

$$Q_w := \begin{cases} P_w & \text{if } w \in \text{St}; \\ B_{w, \lambda_w, 1} & \text{if } w \in \text{Ba}. \end{cases}$$

We have abused notation here by allowing the scalar  $\lambda_w$  to disappear when dealing with  $Q_w$  in the case that  $w$  is a homotopy band; it should be treated as implicitly present.

For  $f \in \text{Hom}_{\mathbf{C}}(Q_v, Q_w)$  and a degree  $t$ , the map  $f^t: Q_v^t \rightarrow Q_w^t$  can be written as a matrix between the finitely-many indecomposable summands of  $Q_v^t$  and  $Q_w^t$ . Each entry of this matrix is a linear combination of paths (see Proposition 1.1). We refer to a single term in this sum as a *component* of  $f^t$ . Moreover, a *component of  $f$*  is taken to be a component of  $f^t$  for some degree  $t$ . Throughout this section we fix two homotopy strings or bands  $v$  and  $w$  and the corresponding complexes  $Q_v$  and  $Q_w$ . We consider ‘maps’ between the unfolded diagrams of  $Q_v$  and  $Q_w$  which, at each projective, will look like:

$$\begin{array}{c} Q_v: \quad \cdots \bullet \xrightarrow{v_L} \bullet \xrightarrow{v_R} \bullet \cdots \\ \quad \quad \quad \quad \quad \quad \quad \downarrow f \\ Q_w: \quad \cdots \bullet \xrightarrow{w_L} \bullet \xrightarrow{w_R} \bullet \cdots \end{array}$$

If  $f$  is at the leftmost end of the unfolded string complex  $Q_v$  we say that  $v_L$  is *zero*; likewise for  $v_R$ ,  $w_L$ , and  $w_R$ . Again,  $f$  is a linear combination of paths and we will use the term *component* to refer to a single summand of  $f$ .

In the next sections we shall define maps occurring in a canonical basis of  $\text{Hom}_{\mathbf{C}}(Q_v, Q_w)$ .

**3.1. Single and double maps.** Suppose we are in the following situation:

$$(1) \quad \begin{array}{c} Q_v: \quad \cdots \bullet \xrightarrow{v_L} \bullet \xrightarrow{v_R} \bullet \cdots \\ \quad \quad \quad \quad \quad \quad \quad \downarrow f \\ Q_w: \quad \cdots \bullet \xrightarrow{w_L} \bullet \xrightarrow{w_R} \bullet \cdots \end{array}$$

where  $f$  is some non-stationary path in the quiver.



**Definition 3.1.** A map in  $\text{Hom}_{\mathbb{C}}(Q_v, Q_w)$  will be called a *single map* if it has only one non-zero component whose unfolded diagram is as above and satisfies the following conditions:

- (L1) If  $v_L$  is direct, then  $v_L f = 0$ .
- (L2) If  $w_L$  is inverse, then  $f w_L = 0$ .
- (R1) If  $v_R$  is inverse, then  $v_R f = 0$ .
- (R2) If  $w_R$  is direct, then  $f w_R = 0$ .

Write  $\mathcal{S}_{v,w}$  for the set of single maps  $Q_v \rightarrow Q_w$ .

**Example 3.2.** Again consider the Running Example. Let

$$v = (dc, 1, 2)(b, 2, 3)(a, 3, 4) \text{ and } w = (e, 2, 1)(f, 1, 0)(c, 0, 1)(b, 1, 2)(af, 2, 3).$$

Then we have the following:

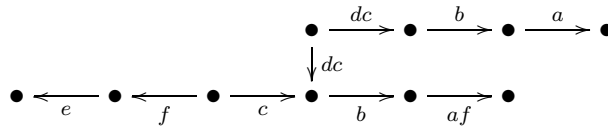

which gives rise to a single map  $P_v \rightarrow P_w$ :

$$\begin{array}{ccccc}
 P(1) & \xrightarrow{dc} & P(4) & \xrightarrow{b} & P(5) & \xrightarrow{a} & P(3) \\
 & \downarrow \begin{pmatrix} dc \\ 0 \end{pmatrix} & & \downarrow \begin{pmatrix} 0 \\ 0 \end{pmatrix} & & \downarrow 0 & \\
 P(3) & \xrightarrow{\begin{pmatrix} c \\ f \end{pmatrix}} & P(4) \oplus P(2) & \xrightarrow{\begin{pmatrix} b & 0 \\ 0 & e \end{pmatrix}} & P(5) \oplus P(1) & \xrightarrow{\begin{pmatrix} af & 0 \end{pmatrix}} & P(2)
 \end{array}$$

Suppose we have the following situation:

$$(2) \quad \begin{array}{ccccccc}
 Q_v: & \cdots & \bullet & \xrightarrow{v_L} & \bullet & \xrightarrow{u_v} & \bullet & \xrightarrow{v_R} & \bullet & \cdots \\
 & & & f_L \downarrow & (*) & \downarrow f_R & & & & \\
 Q_w: & \cdots & \bullet & \xrightarrow{w_L} & \bullet & \xrightarrow{u_w} & \bullet & \xrightarrow{w_R} & \bullet & \cdots
 \end{array}$$

such that  $(*)$  commutes for non-stationary paths  $f_L, f_R$ .

**Definition 3.3.** If (L1) and (L2) hold for  $f_L$  and (R1) and (R2) hold for  $f_R$ , then the diagram above induces a map  $Q_v \rightarrow Q_w$  with two non-zero components in consecutive degrees given by  $f_L$  and  $f_R$ . We call such a map a *double map*; write  $\mathcal{D}_{v,w}$  for the set of double maps  $Q_v \rightarrow Q_w$ .

**Remark 3.4.** To obtain all double maps  $Q_v \rightarrow Q_w$  in terms of diagrams as above, it is necessary to consider overlaps between unfolded diagrams of  $Q_v$  and any  $Q_{w'}$  such that  $Q_w \cong Q_{w'}$ ; see Section 2.4 for the relevant equivalence relations on homotopy strings and bands.

**Example 3.5.** Returning to the Running Example, consider the homotopy strings:

$$v = (dc, -2, -1)(b, -1, 0)(a, 0, 1) \text{ and } w = (af, 3, 2)(b, 2, 1)(c, 1, 0)(f, 0, 1)(e, 1, 2).$$

The unfolded diagram

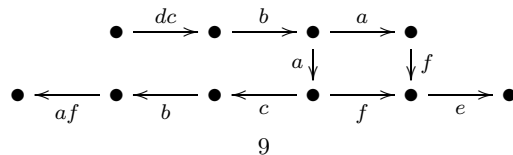

gives rise to the double map:

$$\begin{array}{ccccccc}
P(1) & \xrightarrow{dc} & P(4) & \xrightarrow{b} & P(5) & \xrightarrow{a} & P(3) \\
& & & & a \downarrow & & \downarrow \begin{pmatrix} 0 \\ f \end{pmatrix} \\
& & & & P(3) & \xrightarrow{\begin{pmatrix} c \\ f \end{pmatrix}} & P(4) \oplus P(2) & \xrightarrow{\begin{pmatrix} b & 0 \\ 0 & e \end{pmatrix}} & P(5) \oplus P(1) & \xrightarrow{\begin{pmatrix} a & f \\ 0 \end{pmatrix}} & P(2)
\end{array}$$

**Notation 3.6.** Let  $f \in \mathcal{S}_{v,w}$  and suppose the unique non-zero component of  $f$  corresponds to the path  $p: x \rightsquigarrow y$  in  $\Gamma$ . Then we write  $f = (p)$ . Similarly, for  $f \in \mathcal{D}_{v,w}$  whose two non-zero components correspond to the paths  $p: x \rightsquigarrow y$  and  $q: x' \rightsquigarrow y'$ , we write  $f = (p, q)$ . The notation should be suggestive of an infinite vector, in which all entries are zero apart from those which are written.

We next highlight two important classes of single and double maps.

**Definition 3.7.** Recall the setup in (1). A map  $f \in \mathcal{S}_{v,w}$  will be called a *singleton single map* when its non-zero component is given by a path  $p$  and we are in the situation of the following unfolded diagrams (up to inverting one of the homotopy strings):

$$\begin{array}{ll}
(i) & \begin{array}{c} \cdots \bullet \xrightarrow{v_r} \bullet \\ \downarrow p \\ \bullet \xrightarrow{w_s} \bullet \cdots \end{array} \\
(ii) & \begin{array}{c} \cdots \bullet \xrightarrow{v_{i+1}} \bullet \xrightarrow{v_i} \bullet \cdots \\ \downarrow p \\ \bullet \xrightarrow{w_s} \bullet \cdots \end{array} \\
(iii) & \begin{array}{c} \cdots \bullet \xrightarrow{v_r} \bullet \\ \downarrow p \\ \cdots \bullet \xrightarrow{w_j} \bullet \xrightarrow{w_{j-1}} \bullet \cdots \end{array} \\
(iv) & \begin{array}{c} \cdots \bullet \xrightarrow{v_{i+1}} \bullet \xrightarrow{v_i} \bullet \cdots \\ \downarrow p \\ \cdots \bullet \xrightarrow{w_j} \bullet \xrightarrow{w_{j+1}} \bullet \cdots \end{array} ,
\end{array}$$

where  $r \in \{1, n\}$ ,  $s \in \{1, m\}$ , either  $v_r$  is inverse (or zero) or  $v_r p = 0$ , and either  $w_s$  is inverse (or zero) or  $p w_s = 0$ . We denote the set of all singleton single maps  $Q_v \rightarrow Q_w$  by  $\mathcal{S}_{v,w}^1$ .

**Definition 3.8.** Recall the setup in (2). A map  $f = (f_L, f_R) \in \mathcal{D}_{v,w}$  will be called a *singleton double map* if it satisfies the following condition (or its dual).

(D) There exists a non-stationary path  $f'$  such that  $v_0 = f_L f'$  and  $w_0 = f' f_R$ .

We denote the set of all singleton double maps  $Q_v \rightarrow Q_w$  by  $\mathcal{D}_{v,w}^1$ .

Condition (D) means that to find singleton double maps, it is sufficient to look for homotopy letters  $v_i$  of  $v$  and  $w_j$  of  $w$  such that  $v_i$  and  $w_j$  sit in the same degrees, with the same orientation, and a ‘proper right substring’ of  $v_i$  is a ‘proper left substring’ of  $w_j$ .

**3.2. Graph maps and quasi-graph maps.** Suppose the unfolded diagrams of  $Q_v$  and  $Q_w$  overlap as follows:

$$\begin{array}{l}
\text{degrees:} \qquad \qquad \qquad t_p \qquad t_{p-1} \qquad \qquad \qquad t_1 \qquad t_0 \\
Q_v: \qquad \cdots \bullet \xrightarrow{v_L} \bullet \xrightarrow{u_p} \bullet \xrightarrow{u_{p-1}} \cdots \xrightarrow{u_2} \bullet \xrightarrow{u_1} \bullet \xrightarrow{v_R} \bullet \cdots \\
\qquad \qquad \qquad \downarrow f_L \quad \downarrow \text{(*)} \quad \parallel \quad \parallel \quad \cdots \quad \parallel \quad \parallel \quad \downarrow \text{(**)} \quad \downarrow f_R \\
Q_w: \qquad \cdots \bullet \xrightarrow{w_L} \bullet \xrightarrow{u_p} \bullet \xrightarrow{u_{p-1}} \cdots \xrightarrow{u_2} \bullet \xrightarrow{u_1} \bullet \xrightarrow{w_R} \bullet \cdots \\
\text{degrees:} \qquad \qquad \qquad t_p \qquad t_{p-1} \qquad \qquad \qquad t_1 \qquad t_0
\end{array}$$

such that  $v_L \neq w_L$  and  $v_R \neq w_R$ . The double lines represent isomorphisms and all of the squares with solid lines commute as paths in the quiver. Consider the following *left endpoint conditions*.

- (**LG1**) The arrows  $v_L$  and  $w_L$  are either both direct or both inverse and there exists some (scalar multiple of a) non-stationary path  $f_L$  such that the square  $(*)$  commutes.  
(**LG2**) The arrows  $v_L$  and  $w_L$  are neither both direct nor both inverse. In this case, if  $v_L$  is non-zero then it is inverse and if  $w_L$  is non-zero then it is direct.

There are dual *right endpoint conditions*, which we call (**RG1**) and (**RG2**), respectively.

**Definition 3.9.** If one of (**LG1**) or (**LG2**) hold and one of (**RG1**) or (**RG2**) hold, the diagram induces a map  $Q_v \rightarrow Q_w$ , whose non-zero components are exactly those described by the diagram. Such maps are called *graph maps*; write  $\mathcal{G}_{v,w}$  for the set of graph maps  $Q_v \rightarrow Q_w$ .

**Example 3.10.** Consider the algebra in the Running Example. Let

$$v = (dc, 0, 1)(b, 1, 2)(a, 2, 3) \text{ and } w = (e, 2, 1)(f, 1, 0)(c, 0, 1)(b, 1, 2)(af, 2, 3).$$

The unfolded diagram on the left gives rise to the graph map on the right.

$$\begin{array}{ccccccc}
\bullet & \xrightarrow{dc} & \bullet & \xrightarrow{b} & \bullet & \xrightarrow{a} & \bullet \\
& & \downarrow d & \parallel & \parallel & & \downarrow f \\
\bullet & \xleftarrow{e} & \bullet & \xleftarrow{f} & \bullet & \xrightarrow{c} & \bullet \\
& & & & \parallel & \parallel & \parallel \\
& & & & \bullet & \xrightarrow{b} & \bullet \\
& & & & \parallel & \parallel & \parallel \\
& & & & \bullet & \xrightarrow{af} & \bullet
\end{array}
\quad
\begin{array}{ccccccc}
P(1) & \xrightarrow{dc} & P(4) & \xrightarrow{b} & P(5) & \xrightarrow{a} & P(3) \\
\downarrow d & & \downarrow \begin{pmatrix} 1 \\ 0 \end{pmatrix} & & \downarrow \begin{pmatrix} 1 \\ 0 \end{pmatrix} & & \downarrow f \\
P(3) & \xrightarrow{\begin{pmatrix} c \\ f \end{pmatrix}} & P(4) \oplus P(2) & \xrightarrow{\begin{pmatrix} b \\ 0 \\ 0 \end{pmatrix}} & P(5) \oplus P(1) & \xrightarrow{\begin{pmatrix} af \\ 0 \end{pmatrix}} & P(2)
\end{array}$$

**Definition 3.11.** If none of the conditions (**LG1**), (**LG2**), (**RG1**) nor (**RG2**) hold, then the diagram no longer induces a map, however we shall say that there is a *quasi-graph map* from  $Q_v$  to  $Q_w$ .

**Definition 3.12.** Consider the diagram representing a quasi-graph map  $Q_v \rightarrow \Sigma^{-1}Q_w$ :

$$\begin{array}{ccccccccccc}
Q_v: & \cdots & \bullet & \cdots & \bullet & \xrightarrow{v_L} & \bullet & \xrightarrow{u_p} & \bullet & \xrightarrow{u_{p-1}} & \cdots & \bullet & \xrightarrow{u_2} & \bullet & \xrightarrow{u_1} & \bullet & \cdots & \bullet & \cdots \\
\Sigma^{-1}Q_w: & \cdots & \bullet & \cdots & \bullet & \xrightarrow{w_L} & \bullet & \xrightarrow{u_p} & \bullet & \xrightarrow{u_{p-1}} & \cdots & \bullet & \xrightarrow{u_2} & \bullet & \xrightarrow{u_1} & \bullet & \cdots & \bullet & \cdots \\
& & & & \parallel & & \parallel & & \parallel & & \parallel & & \parallel & & \parallel & & \parallel & & \parallel
\end{array}$$

Then there exist  $p$  single maps  $Q_v \rightarrow Q_w$  given by the paths  $u_p, u_{p-1}, \dots, u_1$  in the appropriate degrees. There are also two (single or double) maps with non-zero components given by  $v_L, w_L, v_R$  or  $w_R$  in the appropriate degree. For example, if  $v_L$  is direct and  $w_L$  is inverse than there is a double map  $(v_L, w_L)$ . We call these maps the associated *quasi-graph map representatives*. Let  $\mathcal{Q}_{v,w}$  be a fixed set of quasi-graph map representatives  $Q_v \rightarrow Q_w$ , one for each quasi-graph map from  $Q_v$  to  $\Sigma^{-1}Q_w$ .

**Example 3.13.** Let us return to the Running Example. Consider the homotopy strings

$$\begin{aligned}
v &= (f, 0, 1)(e, 1, 2)(dc, 2, 3)(b, 3, 4)(a, 4, 5)(d, 5, 4), \text{ and} \\
w &= (c, 0, -1)(f, -1, 0)(e, 0, 1)(dc, 1, 2)(b, 2, 3)(a, 3, 4).
\end{aligned}$$

The following diagram describes a quasi-graph map  $Q_v \rightarrow \Sigma^{-1}Q_w$ :

$$\begin{array}{ccccccccccc}
Q_v: & \bullet & \xrightarrow{f} & \bullet & \xrightarrow{e} & \bullet & \xrightarrow{dc} & \bullet & \xrightarrow{b} & \bullet & \xrightarrow{a} & \bullet & \xleftarrow{d} & \bullet \\
\Sigma^{-1}Q_w: & \bullet & \xleftarrow{c} & \bullet & \xrightarrow{f} & \bullet & \xrightarrow{e} & \bullet & \xrightarrow{dc} & \bullet & \xrightarrow{b} & \bullet & \xrightarrow{a} & \bullet
\end{array}$$

and the associated quasi-graph map representatives  $Q_v \rightarrow Q_w$  are

$$\{(-c), (f), (-e), (dc), (-b), (a), (-d)\}.$$

**Remarks 3.14.** We highlight the following.

- (1) (Quasi-)graph maps extend to infinite homotopy strings in the obvious way; if a left (respectively right) endpoint condition holds and the substrings to the right (respectively left) are equal and infinite then we can define a (quasi-)graph map with infinitely many components which are isomorphisms. Cf. [17] for infinite graph maps between modules.
- (2) To standardise what we mean by a (quasi-)graph map we take the following conventions. If  $v$  and  $w$  are both homotopy strings, then each isomorphism is an identity. If one of  $v$  and  $w$  is a homotopy band, then the leftmost isomorphism in the diagram is an identity and the remaining isomorphisms will be determined by this. Note that any other choice of isomorphisms will result in a scalar multiple of such a standardised map.
- (3) It is necessary to replace  $w$  by an equivalent homotopy string/band to obtain all of the possible (quasi-)graph maps  $Q_v \rightarrow Q_w$ ; cf. Remark 3.4.
- (4) There is one pathological example arising from the identity map  $B_{w,\lambda,1} \rightarrow B_{w,\lambda,1}$ . This is a graph map since it ‘travels’ the whole way around the band. In particular, there are no real endpoint conditions. As such it also defines a quasi-graph map  $B_{w,\lambda,1} \rightarrow \Sigma^{-1}B_{w,\lambda,1}$ . This situation will be treated in more detail in Section 5.

**3.3. The main theorem.** We have now assembled all the maps that occur in a canonical basis of  $\text{Hom}_{\mathbb{D}}(Q_v, Q_w)$  and can state our main result succinctly as the following.

**Theorem 3.15.** *The set  $\mathcal{B}_{v,w}^{\mathbb{D}} := \mathcal{S}_{v,w}^1 \cup \mathcal{D}_{v,w}^1 \cup \mathcal{G}_{v,w} \cup \mathcal{Q}_{v,w}$  is a  $\mathbf{k}$ -linear basis for  $\text{Hom}_{\mathbb{D}}(Q_v, Q_w)$ .*

The next section concerns the proof of this result.

**Example 3.16.** Consider the following homotopy strings over the Running Example:

$$v = (a, -1, 0)(c, 0, 1)(b, 1, 2)$$

$$w = (e, 2, 3)(d, 3, 4)(a, 4, 3)(b, 3, 2)(cd, 2, 1)(e, 1, 0)(f, 0, -1)(c, -1, 0)(b, 0, 1)(a, 1, 2)$$

The set  $\mathcal{B}_{v,w}^{\mathbb{D}}$  has two elements. The first is a singleton single map  $(af)$  in degree 2 from the right end-point of  $v$  to the left end-point of  $w$ . The second is given by the following quasi-graph map  $Q_v \rightarrow \Sigma^{-1}Q_w$ , where the associated quasi-graph map representatives  $Q_v \rightarrow Q_w$  are indicated by dashed arrows (single maps) and dotted arrows (double map):

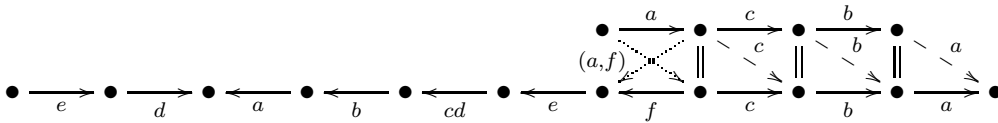

#### 4. PROOF OF THE MAIN THEOREM

Let  $v, w \in \text{St} \sqcup \text{Ba}$  and  $Q_v, Q_w$  be as in the previous section. We shall split up the proof of Theorem 3.15 into two parts. The first part establishes a canonical basis for  $\text{Hom}_{\mathbb{C}}(Q_v, Q_w)$ . In the second part, we identify which elements of this basis are homotopic or null-homotopic.

**4.1. A basis at the level of complexes.** In this section, we establish the following:

**Proposition 4.1.** *The set  $\mathcal{B}_{v,w}^{\mathbb{C}} := \mathcal{G}_{v,w} \cup \mathcal{S}_{v,w} \cup \mathcal{D}_{v,w}$  is a  $\mathbf{k}$ -linear basis for  $\text{Hom}_{\mathbb{C}}(Q_v, Q_w)$ .*

The proof of Proposition 4.1 is inspired by [17, Section 1.4]. We first need two technical lemmas from which we will deduce that  $\mathcal{B}_{v,w}^{\mathbb{C}}$  is a linearly independent set.

**Lemma 4.2.** *Suppose we have the following situation:*

$$\begin{array}{ccccccc}
 \cdots & \bullet & \xrightarrow{v_L} & \bullet & \xrightarrow{v_R} & \bullet & \cdots \\
 & f_L \downarrow & & (*)f_C \downarrow & & (**)\downarrow & f_R \\
 \cdots & \bullet & \xrightarrow{w_L} & \bullet & \xrightarrow{w_R} & \bullet & \cdots
 \end{array}$$

where  $f_C$  is a non-stationary path and  $v_L$  is direct if and only if  $w_L$  is direct; similarly for  $v_R$  and  $w_R$ . If the squares  $(*)$  and  $(**)$  commute, then at most one of  $(*)$  and  $(**)$  has a non-zero commutativity relation.

*Proof.* We analyse the case when all four homotopy letters  $v_L, v_R, w_L$  and  $w_R$  are direct; the remaining cases are analogous.

Suppose  $(*)$  has a non-zero commutativity relation. Then  $v_L f_C = f_L w_L \neq 0$ . It follows that the paths  $f_C$  and  $w_L$  start with in the same arrow. By the definitions of homotopy strings and bands,  $w_L w_R = 0$  and, by condition (4) of gentleness, we must also have that  $f_C w_R = 0$ . That is,  $f_C w_R = v_R f_R = 0$  and  $(**)$  has a zero commutativity relation.

Dually, whenever  $(**)$  has a non-zero commutativity relation,  $(*)$  has a zero commutativity relation.  $\square$

**Lemma 4.3.** *The unfolded diagram giving rise to a graph, single or double map is completely determined by any non-zero component.*

*Proof.* We give a proof for the case where we have a non-zero component of a graph map. The arguments for single and double maps are analogous.

We make use of the diagram from Lemma 4.2. Suppose that  $f_C$  is a non-zero component of a graph map. We show that, if it exists,  $f_L$  is completely determined. Note that if  $v_L$  and  $w_L$  have different orientations then the arrow  $f_L$  does not make sense since the degrees will not match. So suppose  $v_L$  and  $w_L$  are either both direct or both inverse.

Suppose  $f_C$  is an isomorphism and  $v_L$  and  $w_L$  are both direct. Then the square  $(*)$  must commute so  $f_L$  is the unique path such that  $f_L w_L = v_L f_C$  (if the path is stationary then  $f_L$  is an isomorphism). Similarly, when  $v_L$  and  $w_L$  are both inverse then  $f_L$  is the unique path such that  $v_L f_L = f_C w_L$ .

Suppose  $f_C$  is given by a path, then according to Lemma 4.2 we must be at the left or right endpoint of the diagram. If  $v_L$  is direct and  $v_L f_C = 0$ , then we must be at the left end of the diagram and  $f_L = 0$ . If  $v_L f_C \neq 0$ , then we are at the right end of the diagram and  $f_L$  is an isomorphism. Similarly, when  $w_L$  is inverse and  $f_C w_L = 0$ , then  $f_L = 0$ . If  $f_C w_L \neq 0$ , then  $f_L$  is an isomorphism.

We can apply dual arguments to conclude that the diagram is also completely determined to the right (i.e.  $f_C$  determines  $f_R$ ).  $\square$

**Corollary 4.4.** *The set  $\mathcal{B}_{v,w}^C = \mathcal{G}_{v,w} \cup \mathcal{S}_{v,w} \cup \mathcal{D}_{v,w}$  is linearly independent.*

*Proof.* Let  $0 \neq b \in \mathcal{B}_{v,w}^C$ . We show that  $b$  cannot be written as a linear combination of other elements of  $\mathcal{B}_{v,w}^C$ . Suppose  $b = \sum_{i=1}^n k_i b_i$  for pairwise different  $b_1, \dots, b_n \in \mathcal{B}_{v,w}^C$  and  $k_i \in \mathbf{k}$ . Let  $f_C$  be a non-zero component of  $b$ . Then some  $b_i, 1 \leq i \leq n$ , must also have this non-zero component because the algebra is gentle and so only has zero relations. By Lemma 4.3,  $b = b_i$  and so  $k_i = 1$  and  $\sum_{j=1}^{i-1} k_j b_j + \sum_{j=i+1}^n k_j b_j = 0$  as required.  $\square$

*Proof of Proposition 4.1.* It suffices to show that  $\mathcal{B}_{v,w}^C$  spans  $\text{Hom}_{\mathbf{C}}(Q_v, Q_w)$ . Let  $0 \neq h \in \text{Hom}_{\mathbf{C}}(Q_v, Q_w)$ . Then there is some degree  $t$  such that  $h^t: Q_v^t \rightarrow Q_w^t$  has a non-zero component  $h_{ab}^t: P(\varphi_v(a)) \rightarrow P(\varphi_w(b))$ . By the shape of homotopy strings and bands,  $P(\varphi_v(a))$  and  $P(\varphi_w(b))$  are each connected to at most two non-zero components of the differential. We must therefore consider the unfolded diagrams (as in Lemma 4.2 but

with  $h_{ab}^t$  in place of  $f_C$ ). Without loss of generality, assume that  $h_{ab}^t$  is an isomorphism or a scalar multiple of a path. By Lemma 4.3, there is a unique (scalar multiple of an) element of  $\mathcal{B}_{v,w}^C$  with this component and, by Lemma 4.2, this must be a summand of  $h$ . If this is not the whole of  $h$ , then we choose another non-zero component of  $h$  and continue until we have found a complete decomposition of  $h$ . Thus  $h \in \text{Span } \mathcal{B}_{v,w}^C$ .  $\square$

Proposition 4.1 gives us canonical bases for the Hom spaces between indecomposable complexes of  $\mathbf{D}$  considered as objects of  $\mathbf{C}$ . We next turn our attention to homotopy classes of these maps. The following section highlights the strategy of our approach.

**4.2. The strategy for constructing homotopy classes.** We first recall the general definition; we direct the reader to a standard textbook on homological algebra, for example [19, 22] for more information regarding homotopies.

**Definition 4.5.** Let  $(P^\bullet, d^\bullet)$  and  $(Q^\bullet, \partial^\bullet)$  be complexes in  $\mathbf{C}$ . Then maps  $f, g: P^\bullet \rightarrow Q^\bullet$  are said to be *homotopic*, written  $f \simeq g$ , if there are maps  $h^i: P^i \rightarrow Q^{i-1}$  such that  $f^i - g^i = d^i h^{i+1} + h^i \partial^{i-1}$  (where, as before, the maps are composed from left to right, see Remark 2.1). The family of maps  $\{h^i\}$  is called a *homotopy* from  $f$  to  $g$ . If  $g = 0$  then  $f$  is called *null-homotopic*.

Consider a map  $f \in \mathcal{B}_{v,w}^C$  and let  $p$  be a component of  $f$ . We can write down an unfolded diagram representation of this component as follows.

$$\begin{array}{c} Q_v: \quad \cdots \bullet \xrightarrow{v_L} \bullet \xrightarrow{v_R} \bullet \cdots \\ \quad \quad \quad \quad \quad \quad \downarrow p \\ Q_w: \quad \cdots \bullet \xrightarrow{w_L} \bullet \xrightarrow{w_R} \bullet \cdots \end{array}$$

Thus, the corresponding component of a homotopic map must be given by

$$q = p + (\alpha v_L a + \beta v_R b + \gamma c w_L + \delta d w_R),$$

for some scalars  $\alpha, \beta, \gamma, \delta \in \mathbf{k}$  and paths  $a, b, c, d$  in the quiver. If the composition of paths does not make sense we take the corresponding scalar to be zero. For instance, if  $v_L$  is direct then  $\alpha = 0$ . Therefore, in order to construct homotopies between maps in  $\mathcal{B}_{v,w}^C$  it is enough to look at ways to construct the path  $p$  by ‘completing’ differential components.

**Definition 4.6.** We denote by  $\mathcal{H}(f)$  the set of maps  $f'$  such that  $f \simeq f'$  and  $f' = \lambda g$  for some  $g \in \mathcal{B}_{v,w}^C$  and  $\lambda \in \mathbf{k}^*$ .

**Remark 4.7.** The set  $\mathcal{H}(f)$  is not the same as the homotopy class of  $f$ , however, if  $g \simeq f$  then the decomposition of  $g$  into a linear combination of elements of  $\mathcal{B}_{v,w}^C$  will consist of elements of  $\mathcal{H}(f) \cup \mathcal{H}(0)$  only. Hence, it suffices to determine the sets  $\mathcal{H}(f)$ . If  $f$  is non-zero and  $\mathcal{H}(f)$  is a singleton set then we will say that  $f$  belongs to a *singleton homotopy class*.

**4.3. Basic maps  $f$  such that  $\mathcal{H}(f)$  is not singleton.** Here we start with  $f \in \mathcal{S}_{v,w} \cup \mathcal{D}_{v,w}$ ; we shall see in Section 4.4 that we do not need to consider  $f \in \mathcal{G}_{v,w}$ . The reader may find it helpful to recall Definitions 3.9 and 3.11 and the corresponding endpoint conditions.

**Proposition 4.8.** *Suppose  $f \in \mathcal{S}_{v,w} \cup \mathcal{D}_{v,w}$  such that  $\mathcal{H}(f) \neq \{f\}$ . Then  $f$  is not null-homotopic if and only if the elements of  $\mathcal{H}(f)$  are in one-to-one correspondence with the representatives of a quasi-graph map  $Q_v \rightarrow \Sigma^{-1}Q_w$ . Moreover,*

- (1)  $\mathcal{H}(f)$  has a double map on the left if  $v_L \neq 0$  is direct and  $w_L \neq 0$  is inverse.

- (2)  $\mathcal{H}(f)$  has a double map on the right if  $v_R \neq 0$  is inverse and  $w_R \neq 0$  is direct.  
(3) Otherwise,  $\mathcal{H}(f)$  ends with a single map on the left or right.

*Proof.* For simplicity, we consider only the case  $f \in \mathcal{S}_{v,w}$ . The case  $f \in \mathcal{D}_{v,w}$  is similar. The setup is the following, where by abuse of notation we have denoted the map and its unique non-zero component by  $f$ :

$$\begin{array}{c}
Q_v: \quad \cdots \bullet \xrightarrow{v_{-2}} \bullet \xrightarrow{v_{-1}} \bullet \xrightarrow{v_0} \bullet \xrightarrow{v_1} \bullet \cdots \\
f \downarrow \\
Q_w: \quad \cdots \bullet \xrightarrow{w_{-2}} \bullet \xrightarrow{w_{-1}} \bullet \xrightarrow{w_0} \bullet \xrightarrow{w_1} \bullet \cdots
\end{array}$$

As explained in Section 4.2, the components corresponding to  $f$  in any homotopic map can be constructed only from four possible paths  $v'_{-1}, v'_0, w'_{-1}$  or  $w'_0$  illustrated in the following diagrams:

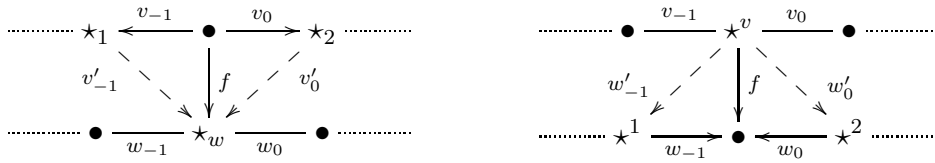

Observe that  $f$  can be immediately seen to be null-homotopic in the following cases:

- (N1) If any of  $v'_{-1}, v'_0, w'_{-1}$  and  $w'_0$  (exist and) are non-stationary paths making one of the triangles commute.
- (N2) If there are no arrows out of  $\star_w$  and either  $f = v_{-1}$  and there is no other arrow in  $v$  into  $\star_1$ , or,  $f = v_0$  and there is no other arrow in  $v$  into  $\star_2$ .
- (N3) If there are no arrows into  $\star^v$  and either  $f = w_{-1}$  and there is no other arrow in  $w$  out of  $\star^1$ , or  $f = w_0$  and there is no other arrow in  $w$  out of  $\star^2$ .

The conditions (N1)–(N3) correspond to the endpoint conditions (LG1), (LG2), (RG1) and (RG2) of Definition 3.9 for graph maps.

Suppose we are not in any of the cases (N1)–(N3). Since  $\mathcal{H}(f) \neq \{f\}$ , at least one, but possibly both, of the following must hold:

- $f$  is built from the source differential, i.e.  $f = v_{-1}$  or  $f = v_0$  (but not both); or
- $f$  is built from the target differential, i.e.  $f = w_{-1}$  or  $f = w_0$  (but not both).

Suppose  $f$  can be built from the source differential; the argument when  $f$  can be built from the target differential is dual. Without loss of generality, we assume  $f = v_0$ ; if  $f = v_{-1}$ , invert the homotopy string  $v$  and re-label  $v_{-1}$  as  $v_0$ . The differential  $v_0$  will be called a *used differential*, because it has already been used to construct one of the single or double maps, namely  $f$  in this instance. There are two cases.

*Case: There are no arrows out of  $\star_w$ .* We must be in the situation that  $w_{-1}$  is direct,  $w_0$  is inverse, and  $v_1$  exists and is inverse – for otherwise we would be in case (N2) above. The following diagram describes the situation.

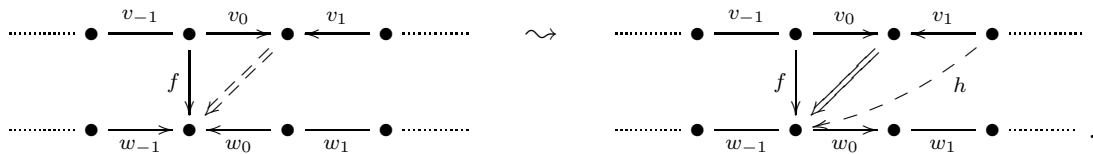

In particular,  $f = (v_0)$  is homotopic to the single map  $-h = -(v_1)$ . We can now see part of the quasi-graph map constructed: namely, the equality written diagonally. We now wish to continue by building  $h$  from a differential. The differential  $v_1$  has already been

used, so in order to continue, we must see whether  $h = w_0$  or  $h = w_{-1}$ , and then use the dual argument for maps built from the target differential.

*Case:* There is an arrow out of  $\star_w$ . Without loss of generality, assume  $w_0 \neq 0$  is direct. Note that only one of  $w_0$  or  $w_{-1}$  may be an arrow out of  $\star_w$  – otherwise  $f$  cannot be a well-defined single map. Then there exists

- a single map  $g = w_0: P(s(v_0)) \rightarrow P(s(w_0))$  if  $v_1$  is direct or zero; or
- a double map  $(h, g) = (v_1, w_0)$ , whenever  $v_1$  is inverse:

The used differentials are  $v_0$  and  $w_0$  in the first case; in the second case  $v_1$  is additionally a used differential. The situation is illustrated below:

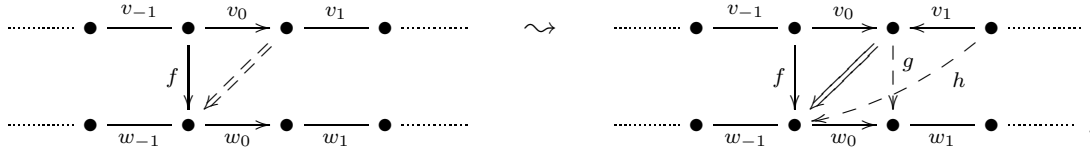

This gives  $-g \in \mathcal{H}(f)$  or  $-(h, g) \in \mathcal{H}(f)$ . If the map we obtain at this step is a single map then we carry on, using the dual argument if necessary, to obtain further elements of  $\mathcal{H}(f)$ . The algorithm terminates when we reach one of the following three cases.

- We reach a single map  $g$  for which one of the conditions (N1), (N2) or (N3) is satisfied. In this case  $f$  is null-homotopic.
- We reach a single map  $g$  which is not equal to any of the unused differentials with respect to the already constructed elements of  $\mathcal{H}(f)$ . This places us in case (3) of the proposition.
- We reach a double map; here there are insufficiently many unused differentials to continue to use to construct a homotopy. This places us in case (1) or (2) of the proposition.

If  $f$  can also be built from the target differential, we must now return to  $f$  and carry out the dual algorithm.  $\square$

**Remark 4.9.** Null-homotopic single and double maps correspond to ‘quasi-graph maps’ which satisfy one of the graph map endpoint conditions.

**Example 4.10.** Recall the quasi-graph map exhibited in Example 3.13. Below is an explicit homotopy from  $(c)$  to  $(dc)$ ; the top line shows this at the level of complexes, the bottom line at the level of unfolded diagrams. In particular, the bottom line indicates how to use a quasi-graph map to construct families of homotopic maps.

$$\begin{array}{cccccccccccc}
 P(0) & \xrightarrow{f} & P(3) & \xrightarrow{e} & P(4) & \xrightarrow{dc} & P(2) & \xrightarrow{(b \ 0)} & P(1) \oplus P(4) & \xrightarrow{\begin{pmatrix} a \\ d \end{pmatrix}} & P(0) \\
 \swarrow 1 & \searrow (c \ 0) & \downarrow (0 \ -1) & \swarrow 0 & \downarrow 1 & \searrow dc & \downarrow 0 & \swarrow 0 & \downarrow 0 & \swarrow 0 & \downarrow 0 \\
 P(0) & \xrightarrow{(c \ f)} & P(2) \oplus P(3) & \xrightarrow{\begin{pmatrix} 0 \\ e \end{pmatrix}} & P(4) & \xrightarrow{dc} & P(2) & \xrightarrow{b} & P(1) & \xrightarrow{a} & P(0)
 \end{array}$$
  

$$\begin{array}{cccccccccccc}
 Q_v: & & \bullet & \xrightarrow{f} & \bullet & \xrightarrow{e} & \bullet & \xrightarrow{dc} & \bullet & \xrightarrow{b} & \bullet & \xrightarrow{a} & \bullet & \xleftarrow{d} & \bullet \\
 \Sigma^{-1}Q_w: & \bullet & \xleftarrow{c} & \bullet & \xrightarrow{f} & \bullet & \xrightarrow{e} & \bullet & \xrightarrow{dc} & \bullet & \xrightarrow{b} & \bullet & \xrightarrow{a} & \bullet & \bullet \\
 & & \parallel 1 & & \parallel -1 & & \parallel 1 & & \parallel dc & & \parallel 0 & & \parallel 0 & & \parallel 0
 \end{array}$$

**4.4. Basic maps  $f$  such that  $\mathcal{H}(f) = \{f\}$ .** We start by observing that graph maps belong to singleton homotopy classes, and thus are never null-homotopic.

**Lemma 4.11.** Suppose  $f \in \mathcal{G}_{v,w}$ . Then  $\mathcal{H}(f) = \{f\}$ .



*Proof.* Suppose  $f \simeq g: Q_v \rightarrow Q_w$ . Since  $f$  is a graph map, there is an unfolded diagram:

$$\begin{array}{cccccccccccc}
Q_v: & \cdots & \bullet & \xrightarrow{v_L} & \bullet & \xrightarrow{u_p} & \bullet & \xrightarrow{u_{p-1}} & \cdots & \xrightarrow{u_2} & \bullet & \xrightarrow{u_1} & \bullet & \xrightarrow{v_R} & \bullet & \cdots \\
& & f_L \downarrow & & f_p \parallel & & f_{p-1} \parallel & & & & & \parallel f_1 & & \parallel f_0 & & \downarrow f_R \\
Q_w: & \cdots & \bullet & \xrightarrow{w_L} & \bullet & \xrightarrow{u_p} & \bullet & \xrightarrow{u_{p-1}} & \cdots & \xrightarrow{u_2} & \bullet & \xrightarrow{u_1} & \bullet & \xrightarrow{w_R} & \bullet & \cdots
\end{array}$$

Without loss of generality, assume that  $f_i = 1$  for  $0 \leq i \leq p$ . Consider the component  $f_i$ . Denote the corresponding component of the map  $g$  by  $g_i$ , which may be zero. Existence of a homotopy between  $f$  and  $g$  means that the difference between  $f_i$  and  $g_i$  is a linear combination,

$$f_i - g_i = 1 - g_i = \alpha u_i a + \beta u_{i+1} b + \gamma c u_i + \delta d u_{i+1},$$

where the  $\alpha, \beta, \gamma, \delta$  are scalars and the  $a, b, c, d$  are paths in the quiver corresponding to the homotopy maps. If the composition does not make sense, we take the corresponding scalar to be zero. Since components of the differential are never zero, the compositions  $u_i a$ ,  $u_{i+1} b$ ,  $c u_i$  and  $d u_{i+1}$  are either zero or non-stationary paths in the quiver. It follows that  $\alpha = \beta = \gamma = \delta = 0$  and  $g_i = 1$ . Lemma 4.3 gives  $f = g$ , whence  $\mathcal{H}(f) = \{f\}$ . If  $i = p$  then this argument should be adjusted in the obvious way.  $\square$

Next we consider singleton homotopy classes of single and double maps. It is clear that a single map  $f \in \mathcal{S}_{v,w}$  is in a singleton homotopy class exactly when its unfolded diagram corresponds to one of (i) – (iv) in Definition 3.7. Therefore, we need only examine when a double map occurs in a singleton homotopy class.

Recall the setup from Section 3.1(2) on page 9. We say that  $f = (f_L, f_R)$  has *no common substring* if  $v_0 = f_L f'$  and  $w_0 = f' f_R$ , and has *common substring*  $s$  if  $f_L = v_0 s$  and  $f_R = s w_0$ . Note that these are the only ways in which the commutative square (\*) in diagram (2) can decompose. Furthermore,  $s$  may be a stationary path, in which case  $f$  has *trivial common substring*.

The following lemma shows that any double map in a singleton homotopy class satisfies condition (D) of Definition 3.8. This then completes the proof of Theorem 3.15.

**Lemma 4.12.** *Let  $f = (f_L, f_R)$  be a double map.*

- (1) *If  $\mathcal{H}(f) \neq \{f\}$ , then  $f$  has a common substring.*
- (2) *If  $f$  has a non-trivial common substring, then  $f$  is null-homotopic.*

*Proof.* Suppose  $\mathcal{H}(f)$  is not a singleton set. Then one of the following must hold:  $v_L v'_L = f_L$ ,  $v_0 v'_0 = f_L$  or  $w'_L w_L = f_L$  for some  $v'_L, v'_0, w'_L$  paths in the quiver. If  $v_0 v'_0 = f_L$ , then since  $f_L w_0 = v_0 f_R$  it follows that  $v_0$  and  $v_L$  start with the same arrow, a contradiction. If  $w'_L w_L = f_L$ , then since  $f_L w_0 \neq 0$ , we must have that  $w_L w_0 \neq 0$ , a contradiction. Thus  $v_0 v'_0 = f_L$  and  $v'_0$  is a non-zero component in the homotopy. But then  $v'_0 w_0 = f_R$  and so  $f$  has a common substring  $v_0$ .

Let  $s$  be a non-trivial common substring for  $f$ , then we can take the required family of maps to be zero everywhere except for the component  $P(s(v_0)) \rightarrow P(t(w_0))$  which is taken to be  $s$ .  $\square$

## 5. HIGHER-DIMENSIONAL BAND COMPLEXES

Each pair  $(w, \lambda) \in \mathbf{Ba} \times \mathbf{k}^*$  determines a homogeneous tube in  $\mathbf{K} \subset \mathbf{D}$ :

$$B_{w,\lambda,1} \begin{array}{c} \xrightarrow{\quad} \\ \xleftarrow{\quad} \end{array} B_{w,\lambda,2} \begin{array}{c} \xrightarrow{\quad} \\ \xleftarrow{\quad} \end{array} B_{w,\lambda,3} \begin{array}{c} \xrightarrow{\quad} \\ \xleftarrow{\quad} \end{array} B_{w,\lambda,4} \begin{array}{c} \xrightarrow{\quad} \\ \xleftarrow{\quad} \end{array} \cdots,$$

where we refer the reader to Section 5.1 for a precise definition of the higher dimensional band  $B_{w,\lambda,r}$  for  $r > 1$ . We shall show that the dimensions of the Hom spaces involving

a higher dimensional band complex can be determined using the dimension of the Hom space of the corresponding one-dimensional band occurring at the mouth of the tube.

We start by making these definitions precise and describing unfolded diagrams for higher dimensional tubes. For simplicity, in this section we shall assume that  $\mathbf{k}$  is an algebraically closed field.

**5.1. Definition, example and unfolded diagrams.** Let  $(w, \lambda, r) \in \mathbf{Ba} \times \mathbf{k}^* \times \mathbb{N}$  and recall that  $B_{w,\lambda,1} := (B_{w,\lambda,1}^i, D^i)$ , with  $D^i = (d_{jk}^i)$ , denotes the one-dimensional band complex. The  $r$ -dimensional band complex is defined as follows:

$$B_{w,\lambda,r} := ((B_{w,\lambda,1}^i)^r, D_{w,\lambda,r}^i),$$

where

$$D_{w,\lambda,r}^i = \begin{pmatrix} D^i & A^i & & 0 \\ 0 & D^i & & 0 \\ & & \ddots & A^i \\ 0 & 0 & & D^i \end{pmatrix}, \text{ and } A^i = (a_{kl}^i) \text{ is given by } a_{kl}^i = \begin{cases} w_1 & \text{if } d_{kl}^i = \lambda w_1; \\ 0 & \text{otherwise.} \end{cases}$$

The *unfolded diagram* of  $B_{w,\lambda,r}$  consists of  $r$  aligned copies of the unfolded diagram of  $B_{w,\lambda,1}$  arranged from top to bottom of the page called *layers*, which are connected by *downwards* arrows corresponding to the non-zero entries of  $A^i$ , called *links*.

**Example 5.1.** Let  $z$  be the homotopy band from the Running Example. The two-dimensional band complex  $B_{z,\lambda,2}$  is

$$(P(0))^2 \xrightarrow{\begin{pmatrix} c & f & 0 & 0 \\ 0 & 0 & c & f \end{pmatrix}} (P(2) \oplus P(3))^2 \xrightarrow{\begin{pmatrix} b & 0 & 0 & 0 \\ 0 & e & 0 & 0 \\ 0 & 0 & b & 0 \\ 0 & 0 & 0 & e \end{pmatrix}} (P(1) \oplus P(4))^2 \xrightarrow{\begin{pmatrix} \lambda a & a \\ d & 0 \\ 0 & \lambda a \\ 0 & d \end{pmatrix}} (P(0))^2 .$$

The corresponding unfolded diagram is:

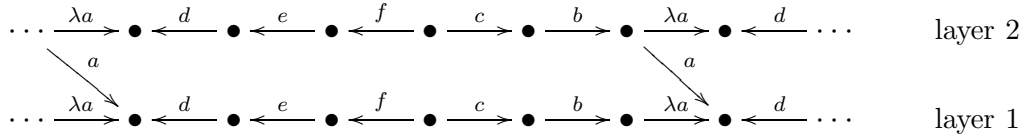

## 5.2. Passing through the link.

**Definition 5.2.** Let  $1 \leq m \leq r$  and  $1 \leq n \leq s$ . We say a map  $f \in \text{Hom}_{\mathbf{D}}(B_{v,\lambda,r}, B_{w,\mu,s})$  is *lifted from a map*  $f' \in \text{Hom}_{\mathbf{D}}(B_{v,\lambda,1}, B_{w,\mu,1})$  *to the pair*  $(m, n)$  if the components of  $f'$  from layer  $m$  of  $B_{v,\lambda,r}$  to layer  $n$  of  $B_{w,\mu,s}$  are exactly the same as the components of  $f$  and  $f$  is the minimal such map in terms of number of non-zero components.

For  $f' \in \text{Hom}_{\mathbf{D}}(B_{v,\lambda,1}, B_{w,\mu,1})$ , we shall count the number of (homotopy classes of) maps in  $\text{Hom}_{\mathbf{D}}(B_{v,\lambda,r}, B_{w,\mu,s})$  which are lifted from  $f'$ . The idea is to put a copy of  $f'$  between the pair  $(m, n)$  of layers and see if a map arises; such a map will be called a *candidate map*. If a component of  $f'$  composes non-trivially with a link arrow, we say that the (candidate) map *passes through the link*. This will cause lifted maps to have non-zero components between more layers than just the pair  $(m, n)$ .

**Lemma 5.3.** *If*  $f \in \text{Hom}_{\mathbf{D}}(B_{v,\lambda,r}, B_{w,\mu,s})$  *then there is a map*  $f' \in \text{Hom}_{\mathbf{D}}(B_{v,\lambda,1}, B_{w,\mu,1})$  *such that*  $f$  *is lifted from*  $f'$  *to a pair*  $(m, n)$ .

*Proof.* As with one-dimensional maps, all maps in  $\text{Hom}_{\mathbf{D}}(B_{v,\lambda,r}, B_{w,\mu,s})$  are completely determined by any of their non-zero components. Ignoring the link arrows between layers, we simply have  $r$  copies of the band in  $B_{v,\lambda,r}$  and  $s$  copies in  $B_{w,\mu,s}$ . It follows that if there



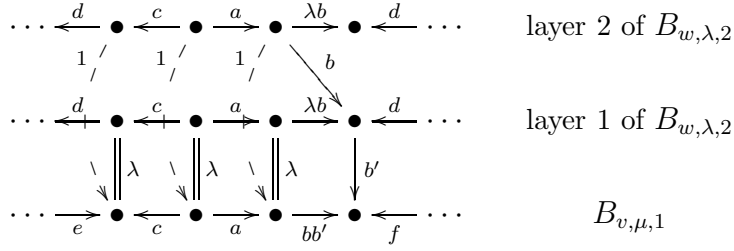

Note that  $h'$  also lifts to a map which includes a copy of  $h'$  from layer 2 of  $B_{w,\lambda,2}$  to the unique layer of  $B_{v,\mu,1}$ . Thus, the graph map  $h'$  lifts to two maps in  $\mathbf{Hom}_{\mathbf{D}}(B_{w,\lambda,2}, B_{v,\mu,1})$ .

Our next example examines the case of lifting a non-singleton homotopy class. Recall the notation for homotopy equivalent basis maps in Definition 5.5.

**Example 5.7.** We consider the homotopy set  $\mathcal{H}((b)) = \{(b), -(\frac{1}{\mu}a), (\frac{1}{\mu}c), -(\frac{1}{\mu}e, \frac{1}{\mu}d)\}$  in  $\mathbf{Hom}_{\mathbf{C}}(B_{v,\lambda,1}, B_{w,\mu,1})$ , contributing one map in  $\mathbf{Hom}_{\mathbf{D}}(B_{v,\lambda,1}, B_{w,\mu,1})$ , which is indicated in the following diagram (drawn without signs or scalars).

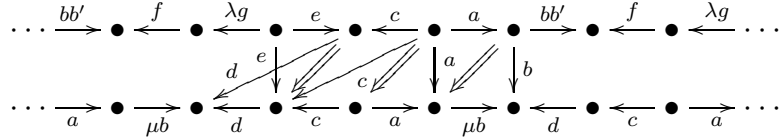

We shall now lift  $\mathcal{H}((b))$  to  $\mathbf{Hom}_{\mathbf{D}}(B_{v,\lambda,1}, B_{w,\mu,2})$ . From Lemma 5.4(1) it is clear that each map in  $\mathcal{H}((b))$  gives rise to two maps in  $\mathbf{Hom}_{\mathbf{C}}(B_{v,\lambda,1}, B_{w,\mu,2})$  without adding any extra components. For convenience, decorate maps to the first layer of  $B_{w,\mu,2}$  with a tilde, i.e.  $\tilde{b}$  and so on, and maps to the second layer with a hat, i.e.  $\hat{b}$  and so on.

By Lemma 5.4, we get  $\tilde{\mathcal{H}}((\tilde{b})) = \{(\tilde{b}), (-\frac{1}{\mu}\tilde{a}), (\frac{1}{\mu}\tilde{c}), -\frac{1}{\mu}(\tilde{e}, \tilde{d})\}$ . We use the following diagram to determine  $\tilde{\mathcal{H}}((\hat{b}))$ .

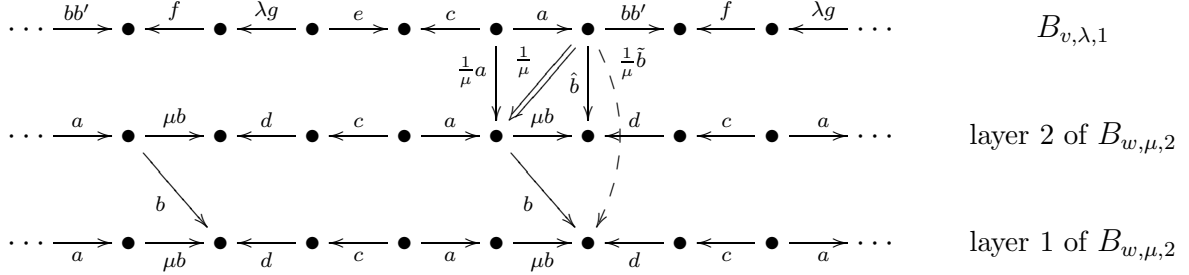

The homotopy passes through the link, so we have  $(\hat{b}) \simeq (-\frac{1}{\mu}\hat{a}) - (\frac{1}{\mu}\tilde{b})$ . It is easy to see that  $(\hat{a}) \simeq (-\hat{c}) \simeq (\hat{e}, \hat{d}) \simeq (-\mu\hat{b})$ . Therefore, we determine  $\tilde{\mathcal{H}}((\hat{b}))$  and  $\tilde{\mathcal{H}}((\hat{a}))$  as follows:

$$\begin{aligned}
\tilde{\mathcal{H}}((\hat{b})) &= \{(\hat{b}), -(\frac{1}{\mu}\hat{a}) - (\frac{1}{\mu}\tilde{b}), (\frac{1}{\mu}\hat{c}) - (\frac{1}{\mu}\tilde{b}), -\frac{1}{\mu}(\hat{e}, \hat{d}) - (\frac{1}{\mu}\tilde{b})\} \\
\tilde{\mathcal{H}}((\hat{a})) &= \{(\hat{a}), -(\hat{c}), (\hat{e}, \hat{d}), -(\mu\hat{b}) - (\tilde{b})\}.
\end{aligned}$$

Now, we have three different homotopy classes, but each of them is a  $\mathbf{k}$ -linear combination of the other two. This shows that such a homotopy class lifts to two homotopy classes of maps in  $\mathbf{Hom}_{\mathbf{C}}(B_{v,\lambda,1}, B_{w,\mu,2})$ , thus giving rise to two maps in  $\mathbf{Hom}_{\mathbf{D}}(B_{v,\lambda,1}, B_{w,\mu,2})$ .

In the next example we look at what happens when one tries to lift an isomorphism. The following example shows that one cannot lift an identity morphism on a one-dimensional homotopy band to every pair of layers  $(m, n)$ .

**Example 5.8.** Consider the homotopy band  $w$  above and let  $\lambda \in \mathbf{k}^*$ . Taking a copy of the identity from layer 1 of  $B_{w,\lambda,2}$  to  $B_{w,\lambda,1}$ , we are forced to take the dashed components as before. However, once we reach the end of the band we must add dashed arrows to the right-hand side of the link as well:

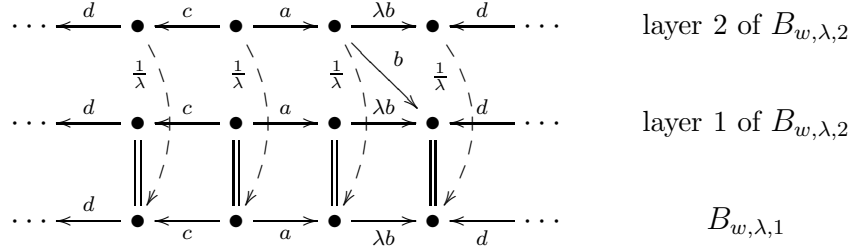

but then the square involving the link does not commute: we have  $2b + \lambda b = b + \lambda b$ . Therefore, we cannot lift a copy of the identity to layer 1 in  $B_{w,\lambda,1}$  and get a well-defined map of homotopy band complexes.

In the final example of this section, we consider the homotopy class arising from the identity map on a one-dimensional band complex.

**Example 5.9.** Consider the complex  $B_{w,\lambda,1}$ . The identity map on  $B_{w,\lambda,1}$  gives rise to a homotopy class in  $\text{Hom}_{\mathbb{D}}(B_{w,\lambda,1}, \Sigma B_{w,\lambda,1})$  which is non-zero:

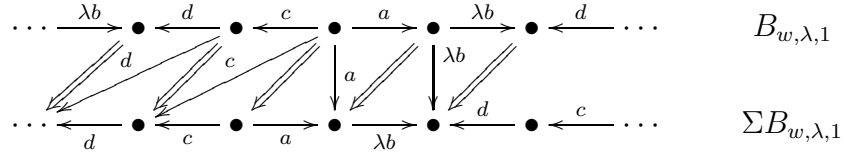

We have  $\mathcal{H}((b)) = \{(b), -\lambda^{-1}(a), \lambda^{-1}(c), -\lambda^{-1}(d), (b)\}$ , where we have written the  $(b)$  twice to emphasise the following key point: this gives a non-trivial way in which to obtain the tautologous homotopy equivalence  $b - b \simeq 0$ . Note that there can be other (homotopy classes of) maps in  $\text{Hom}(B_{w,\lambda,1}, \Sigma B_{w,\lambda,1})$ ; these behave as in Examples 5.6 and 5.7.

**5.4. Maps which are not self-extensions.** In this section we shall make a number of statements regarding dimensions of Hom spaces. It is useful to first set up some notation. Let  $\text{Rad}_{\mathbb{D}}(P^\bullet, Q^\bullet)$  denote the space of non-isomorphisms  $P^\bullet \rightarrow Q^\bullet$ . Following standard notation in algebraic geometry, we write

$$\text{hom}_{\mathbb{D}}(P^\bullet, Q^\bullet) = \dim \text{Hom}_{\mathbb{D}}(P^\bullet, Q^\bullet) \quad \text{and} \quad \text{rad}_{\mathbb{D}}(P^\bullet, Q^\bullet) = \dim \text{Rad}_{\mathbb{D}}(P^\bullet, Q^\bullet).$$

We now state the main result of this section.

**Theorem 5.10.** *Let  $r, s \in \mathbb{N}$ ,  $w, v \in \text{Ba}$ ,  $u \in \text{St}$  and  $\lambda, \mu \in \mathbf{k}^*$  be such that  $B_{v,\lambda,1} \not\cong \Sigma B_{w,\mu,1}$ . Let  $\delta_{B_{v,\lambda,1}, B_{w,\mu,1}}$  be the Kronecker delta. Then*

- (1)  $\text{hom}_{\mathbb{D}}(B_{v,\lambda,r}, B_{w,\mu,s}) = \min\{r, s\} \cdot \delta_{B_{v,\lambda,1}, B_{w,\mu,1}} + rs \cdot \text{rad}(B_{v,\lambda,1}, B_{w,\mu,1})$ ;
- (2)  $\text{hom}_{\mathbb{D}}(B_{v,\lambda,r}, P_u) = r \cdot \text{hom}_{\mathbb{D}}(B_{v,\lambda,1}, P_u)$  and  $\text{hom}_{\mathbb{D}}(P_u, B_{v,\lambda,r}) = r \cdot \text{hom}_{\mathbb{D}}(P_u, B_{v,\lambda,1})$ .

We now prove the first assertion of Theorem 5.10 in a sequence of lemmas; the second assertion is proved similarly. From now on assume that  $v, w \in \text{Ba}$ ,  $\lambda, \mu \in \mathbf{k}^*$  and  $B_{v,\lambda,1} \not\cong \Sigma B_{w,\mu,1}$ .

**Lemma 5.11.** *Let  $0 \neq f' \in \text{Hom}_{\mathbb{D}}(B_{v,\lambda,1}, B_{w,\mu,1})$ . If  $\mathcal{H}(f') = \{f'\}$  and  $f'$  is not an isomorphism, then  $f'$  can be lifted to any pair of layers in  $B_{v,\lambda,r}$  and  $B_{w,\mu,s}$ .*

*Proof.* This follows directly from Lemma 5.4, noting that the resulting maps may acquire extra components if they pass through a link.  $\square$

The following lemmas deal with the generic case of Theorem 5.10; the example to bear in mind is Example 5.7.

**Lemma 5.12.** *Let  $v$  and  $w$  be homotopy bands, and  $\lambda, \mu \in \mathbf{k}^*$  such that  $B_{v,\lambda,1} \neq \Sigma B_{w,\mu,1}$  and  $B_{v,\lambda,1} \neq B_{w,\mu,1}$ . Let  $f^{(m,n)}: B_{v,\lambda,1} \rightarrow B_{w,\mu,1}$  be a lift of  $f \in \mathcal{S}_{v,w} \cup \mathcal{D}_{v,w}$ , which is not null-homotopic, to the layers  $(m,n)$ . Consider the lift  $g^{(m,n)}$  of any map  $g \in \mathcal{H}(f)$ . Then  $g^{(m,n)}$  is homotopic to linear combination of representatives from only  $\tilde{\mathcal{H}}^{(i,j)}(f)$  for  $i \geq m$  and  $j \leq n$ .*

*Proof.* Choose the quasi-graph map in  $\mathcal{Q}_{v,w}$  of which  $f$  is a representative. Starting from the left of the quasi-graph map, we write down the homotopy set

$$\mathcal{H}(f_1) = \{f_1, \dots, \lambda f_p, \dots, \lambda \mu f_q, \dots, \lambda \mu f_k\}.$$

Without loss of generality, we may assume  $f = f_1$ ; taking a different choice simply requires multiplication by the appropriate scalar. Note that our definition above places the link in the source band at  $f_p$  and in the target band at  $f_q$  with  $p < q$ . Other choices of  $p$  and  $q$  can be considered analogously. We consider the following lifts of  $\mathcal{H}(f_1)$ .

$$\tilde{\mathcal{H}}^{(i,j)}(f_1) = \{\tilde{f}_1^{(i,j)}, \dots, \tilde{f}_p^{(i,j)}, \dots, \tilde{f}_q^{(i,j)}, \dots, \tilde{f}_k^{(i,j)}\}$$

where

$$\tilde{f}_t^{(i,j)} := \begin{cases} f_t^{(i,j)} & \text{for } 1 \leq t < p; \\ \lambda f_t^{(i,j)} + f_p^{(i+1,j)} & \text{for } p \leq t < q; \\ \lambda \mu f_t^{(i,j)} + f_p^{(i+1,j)} + f_q^{(i,j-1)} & \text{for } q \leq t \leq k, \end{cases}$$

where we interpret  $f_p^{(i+1,j)} = 0$  for  $i = r$  and  $f_q^{(i,j-1)} = 0$  for  $j = 1$ .

The problem is to write the maps  $f_t^{(i,j)}$  as linear combinations of maps from these sets. For  $f_t^{(i,j)}$  with  $1 \leq t < p$ , there is nothing to show. For  $f_t^{(i,j)}$  with  $p \leq t < q$ , we can write this map as a linear combination of maps from the sets  $\tilde{\mathcal{H}}^{(i,j)}(f_1), \dots, \tilde{\mathcal{H}}^{(r,j)}(f_1)$ . For  $q \leq t \leq k$ , we get  $f_t^{(i,j)}$  as a linear combination of representatives from the sets as above and  $\tilde{\mathcal{H}}^{(i,j-1)}(f_1), \dots, \tilde{\mathcal{H}}^{(i,1)}(f_1)$ , as required.  $\square$

**Lemma 5.13.** *Let  $v$  and  $w$  be homotopy bands, and  $\lambda, \mu \in \mathbf{k}^*$  such that  $B_{v,\lambda,1} \neq \Sigma B_{w,\mu,1}$  and  $B_{v,\lambda,1} \neq B_{w,\mu,1}$ . Then  $\text{hom}_{\mathbb{D}}(B_{v,\lambda,r}, B_{w,\mu,s}) = rs \cdot \text{hom}_{\mathbb{D}}(B_{v,\lambda,1}, B_{w,\mu,1})$ .*

*Proof.* By Lemmas 5.3 and 5.11, we need only check that we have no more than  $rs$  linearly independent non-singleton homotopy classes. Suppose  $f \in \mathcal{S}_{v,w} \cup \mathcal{D}_{v,w}$  is such that  $\mathcal{H}(f) \neq \{f\}$ . If the quasi-graph map determining the representatives of  $\mathcal{H}(f)$  does not pass through the link then it is clear that  $f$  contributes  $rs$  homotopy classes of maps to  $\text{Hom}_{\mathbb{D}}(B_{v,\lambda,r}, B_{w,\mu,s})$ . So we may assume that the quasi-graph map passes through the link in one of the two homotopy bands. Here we assume we are in the generic situation where the quasi-graph map passes through the link in both bands.

Consider the homotopy sets and notation as in the statement and proof of Lemma 5.12 above. Lemma 5.12 shows that any lift of a single or double map homotopic to  $f$  is a linear combination of representatives from  $\tilde{\mathcal{H}}^{(i,j)}(f_1)$  for  $1 \leq i \leq r$  and  $1 \leq j \leq s$ . We just need to establish linear independence.

We claim that every lift of a map in  $\mathcal{H}(f)$  is homotopic to a linear combination of the  $f_q^{(i,j)}$ . First note that any representative in the  $\tilde{\mathcal{H}}^{(r,j)}(f_1)$  is homotopic to a linear combination of the  $f_q^{(r,j)}$  for  $1 \leq j \leq s$  since  $f_p^{(r+1,j)} = 0$  for each  $j$ . Now consider any

representative in the  $\widetilde{\mathcal{H}}^{(r-1,j)}(f_1)$ . Each of these is homotopic to a linear combination of the maps  $f_q^{(r-1,j)}$ ,  $f_q^{(r,j)}$  and  $f_p^{(r,j)}$  for  $1 \leq j \leq s$ . However, we have just shown that  $f_p^{(r,j)}$  is homotopic to a linear combination of the maps  $f_q^{(r,j)}$ . Continuing in this way gives the claim.

Thus, to get linear independence, it is sufficient to show that if  $\sum_{i,j} \alpha_{i,j} f_q^{(i,j)} \simeq 0$  then  $\alpha_{i,j} = 0$  for  $1 \leq i \leq r$  and  $1 \leq j \leq s$ . This can be seen by carrying out the algorithm given in the proof of Proposition 4.8: the required zeros are obtained by the fact that the quasi-graph maps do not satisfy the required null-homotopic (= graph map) endpoint conditions.  $\square$

Next we deal with special case  $B_{v,\lambda,1} = B_{w,\mu,1}$ .

**Lemma 5.14.** *Let  $r$  and  $s$  be positive integers,  $v$  a homotopy band and  $\lambda \in \mathbf{k}^*$ . Then*

$$\text{hom}_{\mathbb{D}}(B_{v,\lambda,r}, B_{v,\lambda,s}) = \min\{r, s\} + rs \cdot \text{rad}(B_{v,\lambda,1}, B_{v,\lambda,1}).$$

*Proof.* By the same arguments as in the proof of Lemma 5.13, any non-isomorphism from  $B_{v,\lambda,1}$  to  $B_{v,\lambda,1}$  can be lifted to any pair of layers  $(m, n)$ . So we must have that  $\text{hom}_{\mathbb{D}}(B_{v,\lambda,r}, B_{v,\lambda,s})$  is at least  $rs \cdot \text{rad}(B_{v,\lambda,1}, B_{v,\lambda,1})$ .

It remains to consider how many maps can be lifted from the identity map. Clearly the identity will pass through the link but, in contrast to non-isomorphism case, the non-zero components acquired in the layers above and below  $n$  and  $m$  will occur on both sides of the link (as in Example 5.8). Thus, if  $f$  is lifted from the identity to  $(m, n)$  for  $1 < m < r$  and  $1 < n < s$ , then  $f$  is also the identity lifted to  $(m+1, n+1)$  and to  $(m-1, n-1)$ .

The identity map does not lift to  $(m, s)$  for  $m \neq r$  nor to  $(1, n)$  for  $n \neq 1$  because it is not possible to satisfy the required commutativity relations, cf. Example 5.8. It follows from this that there are  $\min\{r, s\}$  maps lifted from the identity, each projecting from the top-most layers of  $B_{v,\lambda,r}$  onto the bottom-most layers of  $B_{v,\lambda,s}$ .  $\square$

**5.5. Self-extensions of bands.** As in Lemma 5.14, we must be careful when considering the homotopy class in  $\text{Hom}_{\mathbb{C}}(B_{v,\lambda,1}, \Sigma B_{v,\lambda,1})$  corresponding to the identity in  $\text{Hom}_{\mathbb{C}}(B_{v,\lambda,1}, B_{v,\lambda,1})$ . Here, the example to keep in mind is Example 5.9.

**Lemma 5.15.** *Let  $1 \leq i \leq r$  and  $1 \leq j \leq s$ . Denote the lift of  $(v_1)$  to layers  $(i, j)$  by  $(v_1)^{(i,j)}$ . Then,  $(v_1)^{(i,1)} \simeq 0$  for  $i > 1$  and  $(v_1)^{(i,j-1)} \simeq -(v_1)^{(i+1,j)}$  whenever  $j > 1$ , where we take  $(v_1)^{(r+1,j)} = 0$ .*

*Proof.* The single map  $(v_1): B_{v,\lambda,1} \rightarrow \Sigma B_{v,\lambda,1}$  is a representative of the quasi-graph map corresponding to the identity  $B_{v,\lambda,1} \rightarrow B_{v,\lambda,1}$ . Moreover, this quasi-graph map determines a non-trivial homotopy from  $(v_1)$  to  $(v_1)$ . Lifting this non-trivial homotopy to the pair of layers  $(i, j)$  gives  $(v_1)^{(i,j)} \simeq (v_1)^{(i,j)} - \lambda^{-1}(v_1)^{(i,j-1)} - \lambda^{-1}(v_1)^{(i+1,j)}$ , which outputs the homotopy equivalences as claimed.  $\square$

**Proposition 5.16.** *Let  $r, s \in \mathbb{N}$ ,  $v \in \text{Ba}$  and  $\lambda \in \mathbf{k}^*$ . Then*

$$\text{hom}_{\mathbb{D}}(B_{v,\lambda,r}, \Sigma B_{v,\lambda,s}) = \min\{r, s\} + rs \cdot (\text{hom}_{\mathbb{D}}(B_{v,\lambda,1}, \Sigma B_{v,\lambda,1}) - 1)$$

*Proof.* Observe that every basis element of  $\text{Hom}_{\mathbb{D}}(B_{v,\lambda,1}, \Sigma B_{v,\lambda,1})$  passes through the link at most once except for the quasi-graph map corresponding to the shifted identity. As before, each of these basis elements can be lifted to  $(m, n)$  for any  $m, n$  and so  $\text{hom}_{\mathbb{D}}(B_{v,\lambda,r}, \Sigma B_{v,\lambda,s})$  is at least  $rs \cdot (\text{hom}_{\mathbb{D}}(B_{v,\lambda,1}, \Sigma B_{v,\lambda,1}) - 1)$ . It remains to determine how many linearly independent homotopy classes are lifted from this remaining homotopy class.

Repeated application of Lemma 5.15 yields the following homotopy equivalences:

$$\begin{aligned} (v_1)^{(1,1)} &\simeq -(v_1)^{(2,2)} \simeq (v_1)^{(3,3)} \simeq \dots \simeq \pm(v_1)^{(s,s)}; \\ (v_1)^{(1,2)} &\simeq -(v_1)^{(2,3)} \simeq (v_1)^{(3,4)} \simeq \dots \simeq \pm(v_1)^{(s-1,s)}; \\ &\vdots \\ (v_1)^{(1,s)} &. \end{aligned}$$

Therefore, if  $r \geq s$ , then none of these homotopy equivalences includes a zero map, and therefore none of the homotopy classes above are null. In particular, there are  $s$  homotopy classes. If  $r < s$ , then the first  $s - r$  homotopy classes are actually null-homotopic, which leaves  $s - (s - r) = r$  non-null homotopy classes.

To see that all other lifts of  $(v_1)$  are null-homotopic, we again apply Lemma 5.15. In this case, it yields that  $0 \simeq (v_1)^{(i,1)} \simeq -(v_1)^{(i+1,2)} \simeq (v_1)^{(i+2,3)} \simeq \dots \simeq \pm(v_1)^{(r,s+2-i)}$  for  $2 \leq i \leq r$  when  $r \geq s$ , and  $0 \simeq (v_1)^{(i,1)} \simeq -(v_1)^{(i+1,2)} \simeq (v_1)^{(i+2,3)} \simeq \dots \simeq \pm(v_1)^{(r,r+1-i)}$  for  $2 \leq i \leq r$  when  $r < s$ .

All that remains to show is that lifts of all other single maps occurring as representatives of the quasi-graph map corresponding to  $\text{id}_{B_{v,\lambda,1}}$  are linear combinations of representatives of the homotopy classes described above. This follows directly from Lemma 5.12.  $\square$

Many tubes occurring in representation theory are hereditary. It is natural to ask whether the same is true for the homogeneous tubes that arise from homotopy bands. This can be seen not to be the case using the following straightforward example.

**Example 5.17.** Consider the algebra and homotopy band from the Running Example:

$$z = (d, 3, 2)(e, 2, 1)(f, 1, 0)(c, 0, 1)(b, 1, 2)(a, 2, 3).$$

The unfolded diagram below shows a graph map of degree 3, thus  $\text{Ext}^3(B_{z,\lambda,1}, B_{z,\lambda,1}) \neq 0$ .

$$\begin{array}{cccccccccc} \text{degrees:} & 2 & 3 & 2 & 1 & 0 & 1 & 2 & 3 & 2 \\ \\ B_{z,\lambda,1}: & \bullet & \xrightarrow{\lambda a} & \bullet & \xleftarrow{d} & \bullet & \xleftarrow{e} & \bullet & \xleftarrow{f} & \bullet & \xrightarrow{c} & \bullet & \xrightarrow{b} & \bullet & \xrightarrow{\lambda a} & \bullet & \xleftarrow{d} & \bullet \\ \downarrow & & & & & & & & & & & & & & & & & & \\ \Sigma^3 B_{z,\lambda,1}: & \bullet & \xleftarrow{f} & \bullet & \xrightarrow{c} & \bullet & \xrightarrow{b} & \bullet & \xrightarrow{\lambda a} & \bullet & \xleftarrow{d} & \bullet & \xleftarrow{e} & \bullet & \xleftarrow{f} & \bullet & \xrightarrow{c} & \bullet \\ \text{degrees:} & -2 & -3 & -2 & -1 & 0 & -1 & -2 & -3 & -2 \end{array}$$

## 6. APPLICATION: IRREDUCIBLE MORPHISMS BETWEEN STRING COMPLEXES

In this section, we recover Bobiński's description [9] of the irreducible maps in  $\mathbf{K}$  and extend it to  $\mathbf{D}$ . In [9], Bobiński employed the Happel functor  $F: \mathbf{D} \hookrightarrow \underline{\text{mod}}(\hat{\Lambda})$  to determine the AR structure of  $\mathbf{K} \hookrightarrow \mathbf{D}$ . We present an algorithm intrinsic to  $\mathbf{K}^{-,b}(\text{proj}(\Lambda))$ , which allows one to compute all irreducible maps in  $\mathbf{D}$ . (Note that only the full subcategory of perfect complexes  $\mathbf{K} \hookrightarrow \mathbf{D}$  admits AR triangles.) By [15], it is known that for any  $P \in \text{ind}(\mathbf{K})$ , there are at most two irreducible maps starting and ending at  $P$ .

Recall from [2, 9] that there exist *string functions*  $S, T: \text{St} \rightarrow \{-1, 1\}$  satisfying certain properties (see [2, 9] for precise details). We remark only on the consequences.

- We must consider formal inverses of trivial homotopy strings, say  $(1_x, i, i)^{-1} = (\overline{1}_x, i, i)$ , as distinct homotopy strings; of course they give rise to the same complex.
- For each homotopy string  $w$ , there are unique trivial homotopy strings  $1_x$  and  $1_y$  such that the compositions  $w1_x$  and  $1_y w$  are defined.

We set up some notation and terminology.



**Notation 6.1.** Let  $f = (f_r, \dots, f_0) \in \text{Hom}_{\mathbf{D}}(P_w, P_v)$  be as illustrated below.

$$\begin{array}{c} \cdots \bullet \xrightarrow{w_n} \cdots \xrightarrow{w_l} \bullet \cdots \\ \downarrow f_r \qquad \qquad \qquad \downarrow f_0 \\ \cdots \bullet \xrightarrow{v_{n'}} \cdots \xrightarrow{v_{l'}} \bullet \cdots \end{array}$$

The *support* of  $f$  is the homotopy substring  $\text{supp}(f) := \prod_{k=n}^l (w_k, i_k, j_k)$  of  $w$ . For  $l \leq i \leq n$  we will also say that  $f$  is supported at  $P(\varphi_w(i))$ . If  $f$  has only one non-zero component, say  $f_0: P(\varphi_w(k)) \rightarrow P(\varphi_v(l))$ , we say that  $f$  is supported at  $P(\varphi_w(k))$ .

Recall the definition of antipath from Definition 2.5. A direct (resp. inverse) antipath  $\theta$  is called *maximal* if there is no  $a \in \Gamma_1$  such that  $\theta(a, i, i+1)$  is a direct antipath (resp.  $(a, i, i-1)\theta$  is an inverse antipath).

**Remark 6.2.** (Maximal) antipaths do not have to be finite; however, we cannot compose a homotopy string with an infinite antipath if this takes us outside  $\mathbf{D}$ . In particular, if  $\theta = \theta_1\theta_2 \cdots$  is an infinite direct antipath and  $w$  is a finite homotopy string such that  $w\theta_1$  is defined, then the composition  $w\theta$  is not in  $\mathbf{D}$ . Similarly, if  $\theta = \cdots\theta_2\theta_1$  is an infinite inverse antipath and  $\theta_1w$  is defined, then the composition  $\theta w$  is not in  $\mathbf{D}$ . Note that infinite antipaths correspond to oriented cycles in the quiver with ‘full relations’.

**6.1. Algorithm for determining irreducible maps.** The algorithm is stated here for  $\mathbf{K}$ . We extend it to infinite strings in Section 6.2. Let  $w = \prod_{k=n}^1 (w_k, i_k, j_k) \in \text{St}$ . The strategy of the algorithm is as follows: consider the identity map on  $P_w$ :

$$\begin{array}{c} \bullet \xrightarrow{w_n} \bullet \cdots \cdots \bullet \xrightarrow{w_1} \bullet \\ \parallel \qquad \qquad \qquad \parallel \qquad \qquad \qquad \parallel \\ \bullet \xrightarrow{w_n} \bullet \cdots \cdots \bullet \xrightarrow{w_1} \bullet \end{array}$$

We alter the map ‘from the left’ in a minimal way to get a new map. This gives a new string  $w^+$  and a new map  $f^+: P_w \rightarrow P_{w^+}$ , which may each be zero. However, when they are nonzero, the resulting map will turn out to be irreducible. This deals with one of the two possible irreducible maps. To get the other, we alter the map in a minimal way ‘from the right’. This gives a new string  $w_+$  and a new map  $f_+: P_w \rightarrow P_{w_+}$ , which again may each be zero. At least one of  $f^+$  or  $f_+$  will be nonzero. We explicitly give the algorithm which alters the map in a minimal way ‘from the left’. The algorithm doing this ‘from the right’ is dual.

**Algorithm 6.3.** The algorithm proceeds as follows, where we carry out each step in sequence unless instructed otherwise. The map  $f'$  is defined in each step in Figure 1.

*Step 1:* If there is a direct homotopy letter  $u$  such that  $uw$  is a homotopy string and  $u$  is a maximal path, we set  $w' = uw$ , and go to Step 8.

*Step 2:* Remove the longest direct antipath which is a left substring of  $w$ . Write  $\psi_w := w_n \cdots w_{r+1}$  for this antipath.

*Step 3:* If  $(w_r, i_r, j_r)$  is inverse and there exists  $a \in \Gamma_1$  such that  $w_r a \neq 0$ , then set  $w' = (w_r a, i_r, j_r) \prod_{k=r-1}^1 (w_k, i_k, j_k)$ , and go to Step 8.

*Step 4:* If  $(w_r, i_r, j_r)$  is inverse but there is no  $a \in \Gamma_1$  such that  $w_r a \neq 0$ , then set  $w' = \prod_{k=r-1}^1 (w_k, i_k, j_k)$ , and go to Step 9.

*Step 5:* If  $(w_r, i_r, j_r)$  is direct, then decompose  $w_r = aa'$  with  $a \in \Gamma_1$  and set  $w' = (a', i_r, j_r) \prod_{k=r-1}^1 (w_k, i_k, j_k)$ , and go to Step 8.

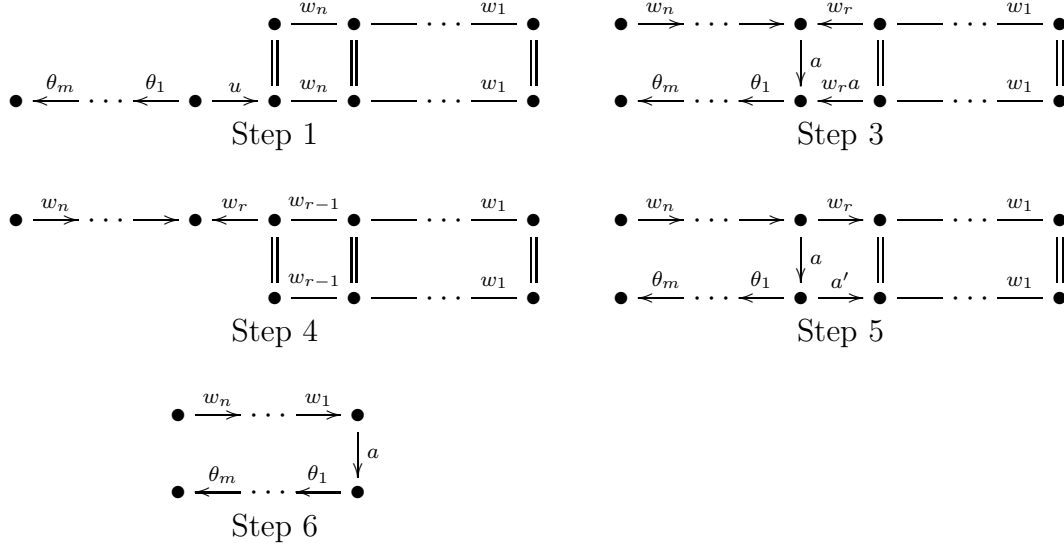

FIGURE 1. Diagrams defining the homotopy strings  $w'$  and maps  $f'$  produced in each step of Algorithm 6.3, with the maximal inverse antipath  $\theta$  of Step 8 also added where appropriate.

*Step 6:* If  $w$  is a direct antipath and there exists  $a \in \Gamma_1$  with  $t(a) = \varphi_w(0)$  with  $w_1 a = 0$ , then set  $w'$  to be the trivial homotopy string such that  $ww'$  is defined, and go to Step 8.

*Step 7:* Set  $f' = f^+$  to be the zero map  $P_w \rightarrow 0$  and terminate the algorithm.

*Step 8:* If there is a maximal inverse antipath  $\theta = \prod_{k=m}^1 (\theta_k, i'_k, j'_k)$  such that  $\theta w'$  is defined as composition of homotopy strings, we set  $w^+ = \theta w'$  and let  $f^+$  have the same components as  $f'$  and terminate the algorithm.

*Step 9:* Set  $f^+ = f'$  and  $w^+ = w'$ .

**Notation 6.4.** We shall refer to the the dual algorithm that alters a homotopy string in a minimal way ‘from the right’ as Algorithm 6.3’; a prime will also be affixed to denote the dual of each of the corresponding steps, i.e. the dual of Step  $i$  is Step  $i'$ .

Note that Step 7 only occurs for homotopy strings that are either trivial or antipaths.

**Remark 6.5.** We highlight the following:

- (1) The maps  $f^+$  and  $f_+$ , when non-zero, are either graph maps or single maps.
- (2) If both  $f^+$  and  $f_+$  are non-zero, then the two maps are different at the level of chain maps. If  $w$  or  $w'$  are trivial, then this is taken care of by the functions  $S$  and  $T$ .
- (3) Whenever there is an  $a \in \Gamma_1$  with  $s(a) = x$ , then Step 1 or its ‘right’ dual will occur when considering the trivial homotopy string  $(1_x, i, i)$ . If there are two arrows  $a$  and  $b$  with  $s(a) = x = s(b)$  then both Step 1 and its dual will occur.
- (4) A case analysis shows that if a maximal antipath  $\theta$  is added in Step 8, then this antipath is finite.

**Theorem 6.6.** *Let  $w$  be a homotopy string, and let  $f^+$  and  $f_+$  be the outputs produced by Algorithm 6.3 and its dual, respectively. If  $f^+$  (respectively  $f_+$ ) is non-zero, then it is irreducible.*

In the remainder of this section, we verify Theorem 6.6 in the case that  $f^+ \neq 0$ . The case  $f_+ \neq 0$  is dual.

**6.2. Irreducible maps involving infinite homotopy strings.** Let  $w \in \mathbf{St}_1 \cup \mathbf{St}_2$ . We extend the above algorithm by possibly extending graph maps to infinite graph maps, and by adding the following step between Step 8 and Step 9:

*Step 8.5:* If there is a maximal, infinite inverse antipath  $\theta = \cdots(\theta_1, i'_1, j'_1)$  such that  $(\theta_1, i'_1, j'_1)w'$  is defined as composition of homotopy strings, we set  $f^+$  to be the zero map  $P_w \rightarrow 0$  and terminate the algorithm.

As commented above, the condition of this step is impossible if  $w$  is a finite homotopy string. Moreover, this step ensures that we never go outside  $\mathbf{D}$ .

**Lemma 6.7.** *If  $w^+ \neq 0$  for some homotopy string  $w$ , then  $w^+$  is in  $\mathbf{St}$  if and only if  $w$  is in  $\mathbf{St}$ .*

*Proof.* The ‘if’ direction is already established. Consider  $v \in \mathbf{St}_1$  such that  $w := {}^\infty v$  is left infinite. When we run the algorithm, we perform Step 2 and remove the left infinite part of  $w$ , which corresponds to a cyclic path  $\rho$ . We will then be able to add an arrow  $a$  in one of Step 3, Step 5 or Step 6 (take  $a$  to be the arrow preceding  $w_{r-1}$  in  $\rho$ ). Next Step 8.5 will occur, since we can always add infinitely many copies of  $\rho$ , but this time as inverse homotopy letters.

If  $v \in \mathbf{St}_1$  and  $w := v^\infty$ , we will never remove the infinite part from  $w$  as it consists of inverse homotopy letters. Hence, if the output  $w^+$  is non-zero, it is also in  $\mathbf{St}_1$ .  $\square$

**Corollary 6.8.** *If  $w$  is a two-sided infinite homotopy string, then there are no irreducible maps in  $\mathbf{D}$  with  $P_w$  as source.*

In the remainder of the section, we consider only irreducible maps in  $\mathbf{K}$ , but it is clear that the irreducible maps involving one-sided homotopy strings will behave in the same way.

**6.3. Non-irreducible maps.** Before verifying Theorem 6.6, we eliminate some maps which can be easily seen to be non-irreducible.

**Proposition 6.9.** *Let  $v, w \in \mathbf{St}$  and  $g \in \mathbf{Hom}_{\mathbf{K}}(P_v, P_w)$ . Then  $g$  is **not** irreducible if:*

- (1)  $g$  is a double map;
- (2)  $g \in \mathcal{G}_{v,w}$  is such that both endpoints are non-isomorphisms;
- (3)  $g = (g_s, \dots, g_0)$  is such that  $g_s = ab$  with  $a, b$  non-stationary paths in  $\Gamma$ ;
- (4)  $g = (g_s, \dots, g_0)$  is such that  $g_0 = ab$  with  $a, b$  non-stationary paths in  $\Gamma$ .

*Proof.* (1) Write  $g = (c, d)$  where  $c$  and  $d$  are paths in the quiver. Then  $g$  is, up to inverting  $v$  and  $w$ , given by the diagram to the left, and the factorisation of  $g$  is given by the diagram to the right.

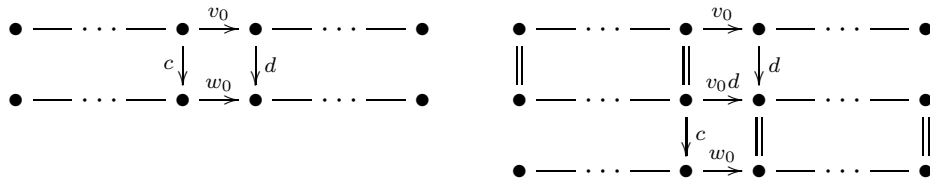

Cases (2), (3) and (4) are similar and can be verified by drawing the corresponding diagrams, noting in (3) and (4) one needs to check only single and graph maps.  $\square$

As a consequence, no single map in the homotopy class of a double map is irreducible. We now examine single maps more closely, giving a necessary condition for irreducibility, which is then used to eliminate further possibilities for irreducible single maps.

**Proposition 6.10.** *If  $g: P_v \rightarrow P_w$  is an irreducible single map, then  $g$  is of the form*

$$(3) \quad \begin{array}{ccc} \cdots & \bullet & \xrightarrow{v_0} & \bullet & \cdots \\ & & & \downarrow a & \\ \cdots & \bullet & \xleftarrow{w_0} & \bullet & \cdots \end{array}$$

*up to inverting  $w$  or  $v$ , where  $a \in \Gamma_1$ , and  $v_0$  and/or  $w_1$  may be zero. Moreover,  $g$  is in a singleton homotopy class; see Definition 3.7.*

*Proof.* Suppose  $g \in \mathcal{S}_{v,w}$  with non-zero support, by abuse of notation, denoted by  $g: P \rightarrow P'$  with  $P, P' \in \text{ind}(\text{proj}(\Lambda))$ . This situation is indicated below.

$$\begin{array}{ccc} \cdots & \bullet & \xrightarrow{v_0} P \xrightarrow{v_1} & \bullet & \cdots \\ & & \downarrow g & & \\ \cdots & \bullet & \xrightarrow{w_0} P' \xrightarrow{w_1} & \bullet & \cdots \end{array}$$

One can easily check that in the following cases,  $g$  is not irreducible:

- $v_0$  and  $v_1$  are both non-zero, or precisely one is non-zero and it has  $P$  as source.
- $w_0$  and  $w_1$  are both non-zero, or precisely one is non-zero and it has  $P'$  as target.

Indeed, if both conditions hold  $g$  factors as two graph maps and one single map (with  $g$  as its non-zero support), and if only one holds then  $g$  factors as one graph map and one single map.  $\square$

**Corollary 6.11.** *Suppose  $g \in \mathcal{S}_{v,w}$  has unfolded diagram taking the form (3) in Proposition 6.10. Then  $g$  is **not** irreducible if:*

- (1)  $v$  (or  $w$ ) is not a uniformly oriented homotopy string;
- (2) any homotopy letter of  $v$  and  $w$  is a path of length longer than 1.

*Proof.* The following diagrams indicate the factorisations:

$$\begin{array}{ccc} \cdots & \bullet & \xleftarrow{v_k} & \bullet & \xrightarrow{v_{k-1}} & \cdots & \xrightarrow{v_0} & \bullet & \cdots \\ & & & \parallel & & & \parallel & & \parallel \\ & & & \bullet & \xrightarrow{v_{k-1}} & \cdots & \xrightarrow{v_0} & \bullet & \cdots \\ & & & & & & & & \downarrow g \\ & & & & & & & & \bullet & \xleftarrow{w_0} & \bullet & \cdots \end{array} \quad \begin{array}{ccc} \cdots & \xrightarrow{ab} & \bullet & \cdots & \xrightarrow{ab} & \bullet & \cdots & \xrightarrow{ab} & \bullet & \cdots \\ & & \downarrow a & & \parallel & & \parallel & & \parallel \\ & & \bullet & \xrightarrow{b} & \bullet & \cdots & \xrightarrow{b} & \bullet & \cdots \\ & & & & & & & & \downarrow g \\ & & & & & & & & \bullet & \xleftarrow{w_0} & \bullet & \cdots \end{array}$$

$\square$

**6.4. Proof of Theorem 6.6.** We start by setting up the notation for the section. Throughout  $w \in \text{St}$ ,  $w'$  and map  $f': P_w \rightarrow P_{w'}$  will be the homotopy string and map output at Steps 1–7, and  $w^+$  and  $f^+: P_w \rightarrow P_{w^+}$  the homotopy string and map output at Steps 7–9. Note that  $f'$  differs from  $f^+$  if and only if  $w^+ = \theta w'$ , where  $\theta = (\theta_m, j_m, i_m) \cdots (\theta_1, j_1, i_1)$  is an inverse antipath. Write  $f^+ = (f_k, \dots, f_0)$  where, using the notation from Algorithm 6.3,  $k \in \{0, r-1, r, n\}$ .

**Lemma 6.12.** *We have the following:*

- (1)  $f^+$  is a well-defined map.
- (2)  $f'$  factors through  $f^+$ .
- (3) For each  $v \in \text{St}$  such that  $vw'$  is defined and such that the components of  $f'$  also determine a map  $g: P_v \rightarrow P_{vw'}$ , the map  $g$  factors through  $f^+$ .

*Proof.* This is easily verified. Observe that if  $f_k$  is the leftmost component of  $f^+$ , and if an antipath was added in Step 8 such that  $f_k \theta_1$  occurs in the diagram, then  $f_k \theta_1 = 0$ .  $\square$

The following lemma shows that if there is a graph map with source  $P_w$  satisfying certain criteria, then at least one of the maps  $f^+$  and  $f_+$  is a graph map.

**Lemma 6.13.** *Let  $w$  be a non-trivial homotopy string. If there exists  $g \in \mathcal{G}_{w,v}$  starting after the left endpoint of  $w$  and stopping with an isomorphism at the right endpoint of  $w$ , then  $f^+$  is a graph map and  $g$  factors through  $f^+$ .*

*Proof.* It follows from the hypotheses of the lemma that  $w$  is not an antipath, so neither Steps 6 nor 7 occur. A straightforward case analysis shows that  $g$  factors through  $f^+$  even if  $v$  is not a homotopy substring of  $w^+$ .  $\square$

**Lemma 6.14.** *Suppose  $f^+ \in \mathcal{G}_{w,w^+}$  and  $g: P_w \rightarrow P_u$  is a map such that  $\text{supp}(g)$  is a homotopy substring of  $\text{supp}(f^+)$ . If  $g$  is not supported on the source of  $f_k$ , then  $g$  factors through  $f^+$ .*

*Proof.* If  $g \in \mathcal{G}_{w,u}$ , then since  $f_{k-1}, \dots, f_0$  are isomorphisms,  $\text{supp}(g)$  is also a homotopy substring of  $w^+$ . It is straightforward to check that the restriction  $g': P_{w^+} \rightarrow P_u$  of  $g$  is also a graph map, and  $g = g'f^+$ . Similarly for  $g \in \mathcal{S}_{w,u}$ .  $\square$

There is a dual statement of Lemma 6.14 for  $f_+$ .

**Lemma 6.15.** *Let  $w \in \text{St}$  be such that  $f^+ \in \mathcal{G}_{w,w^+}$ . If  $g: P_w \rightarrow P_u$  is such that  $\text{supp}(f^+)$  and  $\text{supp}(g)$  have no overlapping part, then  $f_+ \neq 0$  and  $g$  factors through  $f_+$ .*

*Proof.* Write  $g = (g_s, \dots, g_0)$ . Recall the notation from Algorithm 6.3. Only the outputs of Steps 1, 3, 4 and 5 of Algorithm 6.3 are graph maps. We consider these possible termination points in turn.

- At Step 1: Algorithm 6.3 cannot output  $f^+$  at Step 1 under these conditions, since  $\text{supp}(f^+) = w$ .
- At Steps 3 or 5: in these cases  $\text{supp}(g)$  is a substring of  $\psi_w$ . Thus  $w$  contains direct letters and the duals of Steps 6 and 7 cannot occur. In particular, the dual of Algorithm 6.3 outputs a graph map  $f_+$ . Now apply Lemma 6.14.
- At Step 4: the rightmost possible support of  $g_0$  is  $P(\varphi_w(r))$ . If this is not attained, then  $\text{supp}(g)$  is a substring of  $\psi_w$  and one argues as in Step 3 and 5 above.

Suppose the support of  $g_0$  is  $P(\varphi_w(r))$ . If  $g \in \mathcal{S}_{w,u}$  then  $w_n = w_r$  and  $g$  factors through  $f_+$ : Steps 1', 3' and 4' yield a common substring of  $\text{supp}(f_+)$  and  $\text{supp}(f^+)$ , whence we apply Lemma 6.14; and, if Step 6' occurs then we must have  $g_0 = aa'$  where  $a$  is the non-zero component of  $f_+$ , and this gives the desired conclusion. In particular Step 7' never occurs and  $f_+ \neq 0$ .

If  $g \in \mathcal{G}_{w,u}$  we have isomorphisms in all components to the left of  $g_0$ , and the conclusion follows by Lemma 6.13.

Thus,  $f_+ \neq 0$  and  $g$  factors through  $f_+$ , as desired.  $\square$

We are now ready to prove Theorem 6.6.

*Proof of Theorem 6.6.* Let  $w \in \text{St}$  and  $f^+ = (f_k, \dots, f_0)$  and  $w^+$  be the outputs of Algorithm 6.3. The proof is a case analysis. We start with some generalities. Let  $g: P_w \rightarrow P_v$  be another candidate for an irreducible map and note the following.

- Lemmas 6.14 and 6.15 say that any map  $g$  not supported on the source of  $f_k$  factors through  $f^+$  or  $f_+$ , and so is not irreducible.
- Proposition 6.9(1) says that  $g$  must be a graph map or a single map.
- Proposition 6.9(3)(4) and Corollary 6.11(2) say that all components of  $g$  which are not isomorphisms are arrows.

We therefore write  $g = (g_s, \dots, g_0, \dots, g_{-t})$ , where  $g_0$  is the component supported on the source of  $f_k$ ; if  $g$  is a single map then  $g = g_0$ . If  $g \in \mathcal{G}_{w,v}$ , we fix the orientation of  $v$  such that the common substring of  $v$  and  $w$  has the same orientation.

We treat the three possible cases for each step of Algorithm 6.3 which outputs  $f^+$ .

*Case 1: The map  $g$  is a graph map and  $g_0$  is an arrow.*

*Case 2: The map  $g$  is a graph map and  $g_0$  is an isomorphism.*

*Case 3: The map  $g$  is a single map, in which case  $g_0$  must be an arrow.*

It may be useful for the reader to keep Figure 1 on page 26 in mind.

**The map  $f^+$  is output at Step 1.** In this case,  $g_0$  is the leftmost component of  $g$ .

*Case 1:* Clearly,  $g$  factors through  $f^+$  since  $ug_0 = 0$ .

*Case 2:* If  $t < n$  then we simply apply Lemma 6.13 to get  $g$  factoring through  $f_+$ . If  $t = n$  and  $g_{-n}$  is an isomorphism, then  $g$  factors through  $f^+$  by Lemma 6.12. If  $t = n$  and  $g_{-n}$  is an arrow, then it is clear that  $g$  factors through  $f_+$ .

*Case 3:* For  $g = g_0$  to be irreducible we need  $w_n$  to be inverse or trivial by Proposition 6.10. If  $w_n$  is inverse,  $g$  cannot factor through  $f^+$  since  $ug \neq 0$ . If  $f_+$  is a graph map then  $g$  factors through  $f_+$  by Lemma 6.14. If  $f_+$  is a single map, then it is the output of Step 6', in which case  $g_0$  is the non-zero component of  $f_+$  and the factorisation follows. If  $w_n$  is trivial then  $w$  is trivial and  $P_w$  is a stalk complex. It can then be easily checked that  $g$  factors through  $f^+$  or  $f_+$ .

**The map  $f^+$  is output at Step 3.** Here  $w$  is non-trivial and  $g_0$  need not be the leftmost non-zero component of  $g$ .

*Case 1:* Here  $g_0$  is either the leftmost or rightmost non-zero component of  $g$ . In the former case  $w_r g_0 \neq 0$  and  $g_0 = a$  (in the notation of Algorithm 6.3). By Proposition 6.9(2), we may assume that  $g_{-t}$  is an isomorphism. Now  $g$  factors through  $f^+$  by Lemma 6.12 if  $t < r$ . If  $t = r$ ,  $f_+$  is a graph map (argue as in Lemma 6.13), and the conclusion follows by Lemma 6.14.

*Case 2:* In this case  $g$  does not factor through  $f^+$ . The components  $g_{-1}, \dots, g_{-t+1}$  are isomorphisms;  $g_{-t}$  may be an arrow. The  $g_s, \dots, g_1$  are all isomorphisms if  $\psi_w$  is non-trivial, and zero otherwise. If  $f_+$  is a graph map then  $g$  factors through  $f_+$  by Lemma 6.13. If  $f_+$  is not a graph map, then  $\prod_{k=r}^1 (w_k, i_k, j_k)$  is an inverse antipath, which implies  $g_{-t}$  is an isomorphism. It follows that  $w = u$  since adding anything to the endpoints forces either  $f^+$  to be output in Step 1, or a graph map  $f_+$  in Step 1', whence  $g$  is an isomorphism.

*Case 3:* Apply the same argument as when  $g_0$  was the rightmost non-zero component of  $g$  in Case 1.

**The map  $f^+$  is output at Step 4.** Here Cases 1 and 3 are straightforward. For Case 1 apply Lemma 6.14. For Case 3 it is immediate that  $g$  factors through  $f^+$ .

*Case 2:* If  $g_0$  is the leftmost non-zero component then by previously given arguments,  $g$  factors through  $f^+$ . So assume not: we must have that  $g_1$  is an isomorphism, for otherwise  $f^+$  would have been output at Step 3. Applying the argument as in Case 2 above,  $g_s, \dots, g_1$  are each isomorphisms. If  $t < r - 1$  then  $g$  factors through  $f_+$  by Lemma 6.14. If  $t = r - 1$ ,  $g$  is either an isomorphism or else Algorithm 6.3' outputs  $f_+$  at Step 1', whence  $g$  clearly factors through  $f_+$ .

**The map  $f^+$  is output at Step 5.** Here  $f_+$  cannot be output at Step 6' of Algorithm 6.3' since  $w_r$  is direct, so  $f_+$  is a graph map. For Case 2, argue as in Case 2 above. Case 3 is again a straightforward verification.

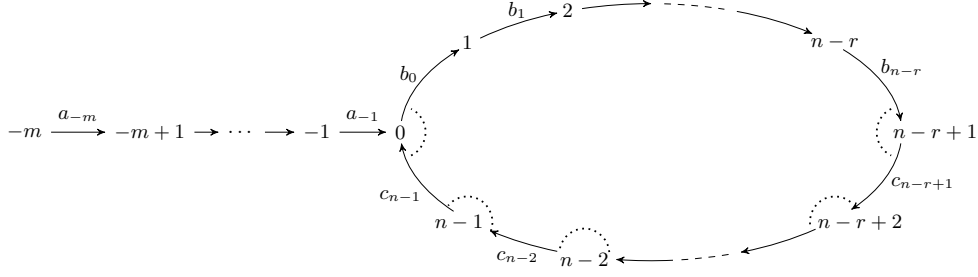

FIGURE 2. The bound quiver defining  $\Lambda(r, n, m)$ .

*Case 1:* If  $g_0$  is the leftmost non-zero component, then  $g_0 = a$  (in the notation of Algorithm 6.3) factors through  $f^+$ . If  $g_0$  is the rightmost non-zero component then use Lemma 6.13.

**The map  $f^+$  is output at Step 6.** Note that the direct antipath  $w$  may be trivial.

*Case 1 and 3:* If  $g_0 \neq a$  (in the notation of Algorithm 6.3) then in the graph map case  $g$  factors through  $f^+$  by Lemma 6.13. In the single map case,  $w$  is a trivial homotopy string and  $g$  factors through  $f_+$ , which is output either at Step 1' or Step 6' of Algorithm 6.3'. Similarly when  $g_0 = a$ .

*Case 2:* Here, the isomorphism  $g_0$  is dragged down the entire homotopy string so that  $v$  has the form  $v = \cdots cwd \cdots$  for some homotopy letters  $c$  and  $d$ . The homotopy letter  $c$  cannot be direct ( $f^+$  would be output at Step 1) nor inverse ( $g$  would not be a map). Similarly,  $d$  is not direct. Hence  $v = wd \cdots$ . If  $d$  is trivial then  $g$  is an isomorphism. If  $d$  is inverse then  $f_+$  is output at Step 1' and  $g$  clearly factors through  $f_+$ .

**The map  $f^+ = 0$  is output at Step 7.** One now applies the dual arguments for  $f_+$  to get the required factorisation through  $f_+$ .  $\square$

## 7. APPLICATION: DISCRETE DERIVED CATEGORIES

For the definition and background on discrete derived categories we refer the reader to [11, 13, 21]. Derived-discrete algebras are derived equivalent to either path algebras of simply-laced Dynkin quivers or the bound path algebra  $\Lambda(r, n, m)$  defined in Figure 2; when we refer to discrete derived categories, we shall always mean  $\mathbf{D}^b(\Lambda(r, n, m))$ .

In this section, we recover the universal Hom-space dimension bound described in [13] when  $\Lambda(r, n, m)$  is of finite global dimension and extend it to the case  $\Lambda(r = n, n, m)$ , which has infinite global dimension. Recall from [8] that  $\Lambda(r, n, m)$  has no homotopy bands. From now on  $\Lambda := \Lambda(r, n, m)$  and  $\text{St}(\Lambda)$  will denote homotopy strings over  $\Lambda$ .

A *subword* of a homotopy string  $w$  is defined in the obvious fashion: the left- and rightmost homotopy letters of the subword may be (incomplete) substrings of the corresponding letters of  $w$ . We now describe all the homotopy strings for a discrete derived category. Note that, when  $r = n$ , by our labelling convention there are no 'b' arrows.

**Lemma 7.1.** *Consider the following homotopy strings:*

$$\begin{aligned}
 w_k: & \quad \bullet \xleftarrow{a_{-1} \dots a_{-m}} \circ \xrightarrow{v_k} \circ \xrightarrow{c_{n-1}} \dots \xrightarrow{c_{n-r+1}} \bullet \xrightarrow{b_{n-r} \dots b_0 a_{-1} \dots a_{-m}} \bullet \\
 w: & \quad \dots \xrightarrow{c_{n-1}} \bullet \xrightarrow{c_{n-2}} \dots \xrightarrow{c_0} \bullet \xrightarrow{c_{n-1}} \bullet \xrightarrow{c_{n-2}} \dots \xrightarrow{c_1} \bullet \xrightarrow{c_0 a_{-1} \dots a_{-m}} \bullet
 \end{aligned}$$

where  $v_k$  is the  $k$ -fold concatenation of  $\bullet \xrightarrow{c_{n-1}} \dots \xrightarrow{c_{n-r+1}} \bullet \xrightarrow{b_{n-r} \dots b_0} \bullet$ . Then:

- (1) if  $r < n$ , all homotopy strings are (shifted) copies of subwords of the  $w_k$  for  $k \geq 0$ ;
- (2) if  $r = n$ , all homotopy strings are (shifted) copies of subwords of  $w$  and  $w_k$  for  $k \geq 0$ .

**Lemma 7.2.** *If  $r > 1$  we have  $\text{hom}_\Lambda(P(i), P(j)) \leq 1$  for all  $-m \leq i, j < n$ . If  $r = 1$  we have additionally  $\text{hom}_\Lambda(P(0), P(j)) = 2$  for all  $-m \leq j \leq 0$ .*

**Lemma 7.3.** *Suppose  $v, w \in \text{St}(\Lambda)$  and consider the following unfolded diagram:*

$$(*) \quad \begin{array}{cccccccccccccccc} \cdots & \bullet & \xrightarrow{v'_L} & \bullet & \xrightarrow{v_L} & \bullet & \xrightarrow{u_p} & \bullet & \xrightarrow{u_{p-1}} & \cdots & \xrightarrow{u_2} & \bullet & \xrightarrow{u_1} & \bullet & \xrightarrow{v_R} & \bullet & \xrightarrow{v'_R} & \cdots \\ & & & & \downarrow f_L & \parallel & & \parallel & & & & \parallel & & \parallel & & \downarrow f_R & & & \\ \cdots & \bullet & \xrightarrow{w'_L} & \bullet & \xrightarrow{w_L} & \bullet & \xrightarrow{u_p} & \bullet & \xrightarrow{u_{p-1}} & \cdots & \xrightarrow{u_2} & \bullet & \xrightarrow{u_1} & \bullet & \xrightarrow{w_R} & \bullet & \xrightarrow{w'_R} & \cdots \end{array}$$

- (1) Suppose  $(*)$  represents a quasi-graph map  $P_v \rightarrow \Sigma^{-1}P_w$ . If  $v_L$  is non-zero, then one of  $v'_L$  or  $w'_L$  is zero.
- (2) Suppose  $(*)$  represents a graph map  $P_v \rightarrow P_w$ . Then either
  - (i)  $f_L \neq 0$  and one of  $v'_L$  or  $w'_L$  is zero; or
  - (ii)  $f_L = 0$  and if  $v_L$  is non-zero then  $v_L = (a_{-1} \dots a_{-i})^{-1}$  for some  $1 \leq i \leq m$ .

*Dual statements hold for the right-hand end of the diagram.*

*Proof.* Recall from Definition 3.11 that if  $v_L$  is not zero then  $v_L \neq w_L$ . We note that the only ways that  $v_L$  and  $w_L$  can differ is if one of them is zero or if one (or both) of them is a subpath of  $b_{n-r} \dots b_0 a_{-1} \dots a_{-m}$ , and it is clear that in all cases one of  $v'_L$  or  $w'_L$  is zero. This shows (1); (2) is similar.  $\square$

The upshot of Lemma 7.3 is that any graph map  $P_v \rightarrow P_w$  or quasi-graph map  $P_v \rightarrow \Sigma^{-1}P_w$  spans every degree where  $P_w$  and  $P_v$  are both non-zero.

**Theorem 7.4.** *Suppose  $v, w \in \text{St}(\Lambda)$ . If  $r > 1$  then  $\text{hom}_{\text{D}^b(\Lambda)}(P_v, P_w) \leq 1$ . If  $r = 1$  then  $\text{hom}_{\text{D}^b(\Lambda)}(P_v, P_w) \leq 2$ .*

*Proof.* For  $r > 1$ , observe that Lemma 7.2 combines with Lemmas 4.3 and 7.3 to give  $\text{hom}_{\text{D}^b(\Lambda)}(P_v, P_w)$  in the cases that there is a graph map  $P_v \rightarrow P_w$  or a non-singleton homotopy class  $P_v \rightarrow P_w$ .

For  $r \geq 1$ , we claim that if there is a single or double map  $f: P_v \rightarrow P_w$  such that  $\mathcal{H}(f)$  is a singleton homotopy class, then  $\text{hom}_{\text{D}^b(\Lambda)}(P_v, P_w) = 1$ . If  $f$  is a single map, a case analysis reveals that, of the options presented in Definition 3.7, only (i) could arise. Clearly, there can be no other basis maps  $P_v \rightarrow P_w$ . Similarly, by considering all of the possible cases where  $f$  is a double map, we find that either  $v$  or  $w$  is a homotopy string of length 1 and that in each of these cases there is no other possible basis map.

When  $r = 1$ , the only way there can be more than one basis map  $P_v \rightarrow P_w$  is if there is a graph map and a single map supported in the same degree, both the graph map and the homotopy class containing this single map will span the rest of the string, by Lemmas 4.3 and 7.3.  $\square$

**Example 7.5.** The following example shows that the upper bound can be attained. Let  $\Lambda = \Lambda(1, 1, 3)$  and consider the homotopy strings  $v = (b_2 b_1 b_0, 2, 3)(b_2 b_1 b_0 a_{-1}, 3, 4)$  and  $w = (a_{-1}, 2, 1)(b_2 b_1 b_0, 1, 2)(b_2 b_1 b_0, 2, 3)(b_2 b_1 b_0 a_{-1}, 3, 4)$ . Pictured below, from left to right: The algebra  $\Lambda(1, 1, 3)$ , a graph map  $P_v \rightarrow P_w$ , and a quasi-graph map  $P_v \rightarrow \Sigma^{-1}P_w$ .

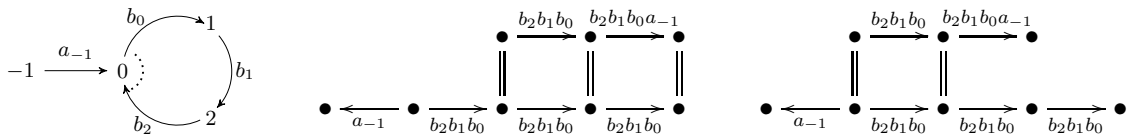



## REFERENCES

- [1] F. Babaei Alitappeh. *Special biserial cluster-tilted algebras and derived categories of cluster-tilted algebras of type A*. PhD thesis, Norwegian University of Science and Technology, Department of Mathematical Sciences, 2014.
- [2] K. K. Arnesen and Y. Grimeland. The Auslander-Reiten components of  $\mathcal{K}^b(\text{proj } \Lambda)$  for a cluster-tilted algebra of type  $\tilde{A}$ . *J. Algebra Appl.*, 14(1), 2015.
- [3] I. Assem, T. Brüstle, G. Charbonneau-Jodoin, and P-G. Plamondon. Gentle algebras arising from surface triangulations. *Algebra Number Theory*, 4(2):201–229, 2010.
- [4] I. Assem and A. Skowroński. Iterated tilted algebras of type  $\tilde{A}_n$ . *Math. Z.*, 195(2):269–290, 1987.
- [5] D. Avella Alaminos and C. Geiß. Combinatorial derived invariants for gentle algebras. *J. Pure Appl. Algebra*, 212(1):228–243, 2008.
- [6] J. Bastian. Mutation classes of  $\tilde{A}_n$ -quivers and derived equivalence classification of cluster tilted algebras of type  $\tilde{A}_n$ . *Algebra Number Theory*, 5(5):567–594, 2011.
- [7] A. A. Beilinson. Coherent sheaves on  $\mathbf{P}^n$  and problems in linear algebra. *Funktsional. Anal. i Prilozhen.*, 12(3):68–69, 1978.
- [8] V. Bekkert and H. A. Merklen. Indecomposables in derived categories of gentle algebras. *Algebr. Represent. Theory*, 6(3):285–302, 2003.
- [9] G. Bobiński. The almost split triangles for perfect complexes over gentle algebras. *J. Pure Appl. Algebra*, 215(4):642–654, 2011.
- [10] G. Bobiński. The graded centers of derived discrete algebras. *J. Algebra*, 333:55–66, 2011.
- [11] G. Bobiński, C. Geiß, and A. Skowroński. Classification of discrete derived categories. *Cent. Eur. J. Math.*, 2(1):19–49 (electronic), 2004.
- [12] G. Bobiński and H. Krause. The Krull-Gabriel dimension of discrete derived categories. *arXiv:1402.1596*, 2014.
- [13] N. Broomhead, D. Pauksztello, and D. Ploog. Discrete derived categories I: Homomorphisms, auto-equivalences and t-structures. *arXiv:1312.5203*, 2013.
- [14] N. Broomhead, D. Pauksztello, and D. Ploog. Discrete derived categories II: The silting pairs CW complex and the stability manifold. *arXiv:1407.5944*, 2014.
- [15] M. C. R. Butler and C. M. Ringel. Auslander-Reiten sequences with few middle terms and applications to string algebras. *Comm. Algebra*, 15(1-2):145–179, 1987.
- [16] W. W. Crawley-Boevey. Maps between representations of zero-relation algebras. *J. Algebra*, 126(2):259–263, 1989.
- [17] W. W. Crawley-Boevey. Infinite-dimensional modules in the representation theory of finite-dimensional algebras. In *Algebras and modules, I (Trondheim, 1996)*, volume 23 of *CMS Conf. Proc.*, pages 29–54. Amer. Math. Soc., Providence, RI, 1998.
- [18] D. Happel. *Triangulated categories in the representation theory of finite-dimensional algebras*, volume 119 of *London Mathematical Society Lecture Note Series*. Cambridge University Press, Cambridge, 1988.
- [19] P. J. Hilton and U. Stambach. *A course in homological algebra*, volume 4 of *Graduate Texts in Mathematics*. Springer-Verlag, New York, second edition, 1997.
- [20] H. Krause. Maps between tree and band modules. *J. Algebra*, 137(1):186–194, 1991.
- [21] D. Vossieck. The algebras with discrete derived category. *J. Algebra*, 243(1):168–176, 2001.
- [22] C. A. Weibel. *An introduction to homological algebra*, volume 38 of *Cambridge Studies in Advanced Mathematics*. Cambridge University Press, Cambridge, 1994.

INSTITUTT FOR MATEMATISKE FAG, NORGES TEKNISK-NATURVITENSKAPELIGE UNIVERSITET, N-7491 TRONDHEIM, NORWAY.

*E-mail address:* kristin.arnesen@math.ntnu.no

SCHOOL OF MATHEMATICS, THE UNIVERSITY OF MANCHESTER, OXFORD ROAD, MANCHESTER, M13 9PL, UNITED KINGDOM.

*E-mail address:* rosanna.laking@manchester.ac.uk

SCHOOL OF MATHEMATICS, THE UNIVERSITY OF MANCHESTER, OXFORD ROAD, MANCHESTER, M13 9PL, UNITED KINGDOM.

*E-mail address:* david.pauksztello@manchester.ac.uk